

## ICE 2V

Counter Top Ice Cream Scoop

### Features and Benefits

- Manual Defrost
- Hinged Lid
- Accepts 2 x 5ltr napoli pans (not supplied)
- Adjustable Temperature

### Technical Specifications

Temperature Range	-10/-20°C
Refrigerant	R404A
Type of Defrost	Manual
Exterior Finish	White
Interior Finish	White
Power Required	13 amp Supply



<b>External Dimensions</b>	<b>Height:</b>	<b>Width:</b>	<b>Depth:</b>	<b>Capacity:</b>	<b>Weight:</b>
ICE 2V	385mm	470mm	700mm	2x5ltr	28kg
<b>Internal Dimensions</b>			<b>Max No of Pans</b>		
ICE 2V	170mm	370mm	390mm	2	

MODEL	Description	Price
ICE 2V	White	£550

## SLANT 510

Scoop Ice Cream Display

### Features and Benefits

- Interior Light
- Accepts 5 Litre Napoli Pans (Not Supplied)
- High Storage Capacity
- Sliding Glass Lids

### Technical Specifications

Temperature Range	-18°C
Refrigerant	R507
Type of Defrost	Manual
No of Bins on Display	
SLANT 510	6
Exterior Finish	White
Interior Finish	White
Power Required	13 Amp Supply



<b>External Dimensions</b>	<b>Height:</b>	<b>Width:</b>	<b>Depth:</b>	<b>Capacity:</b>
SLANT 510	1235mm	1341mm	687mm	6x5ltr Pans
<b>Internal Dimensions</b>			<b>Max No of Pans under display</b>	
SLANT 510	630mm	1217mm	563mm	6

MODEL	Description	Price
SLANT 510LUX	White	£897

## TOP 6E & 7E

Scoop Ice Cream Display

### Features and Benefits

- Fully Automatic Operation
- Electronically Controlled
- Interior Light
- Accepts 5 Litre Napoli Pans (Not Supplied)
- High Storage Capacity (Understorage)
- Fitted Castors
- Optional Scoop Wash (Needs Water & Waste Connection) POA
- Adjustable Temperature

### Technical Specifications

Temperature Range	-18°C
Refrigerant	R507
Type of Defrost	Electric
No of Bins on Display	
TOP 6E	6
TOP 7E	7
Exterior Finish	White
Interior Finish	Painted Steel
Power Required	13 Amp Supply



Top 6E

Top 7E



External Dimensions	Height:	Width:	Depth:	Capacity:	Weight:
TOP 6E	1175mm	1217mm	700mm	96ltr. (3.4cu.ft.)	95kg
TOP 7E	1175mm	1363mm	700mm	121ltr. (4.3cu.ft.)	99kg
Internal Dimensions			Max No of Pans	under display	
TOP 6E	744mm	1067mm	498mm	8	
TOP 7E	744mm	1217mm	498mm	12	
Height from back to rear shelf - 914mm					

MODEL	Description	Price	MODEL	Description	Price
TOP 6E	White	£1029	TOP 7E	White	£1080

### Features and Benefits

- Fully Automatic Operation
- Electronically Controlled
- Accepts 5 Litre Napoli Pans (Not Supplied)
- High Storage Capacity (Double Layer & Understorage)
- Fitted Castors for Easy Movement
- Interior Light
- Adjustable Temperature

### Technical Specifications

Temperature Range	-18°C
Refrigerant	R507
Type of Defrost	Electric
No of Bins on Display	
J7E	7
J9E	9
Maximum No of Pans in Under Storage	
J7E	12
J9E	16
Exterior Finish	White
Interior Finish	Coated Steel
Power Required	13 Amp Supply

External Dimensions	Height:	Width:	Depth:	Capacity:	Weight:
J7E	1224mm	1341mm	723mm	7+7 5ltr Pans	117kg
J9E	1224mm	1656mm	723mm	9+9 5ltr Pans	150kg

## J RANGE

Scoop Ice Cream Display



J7E



MODEL	Description	Price	MODEL	Description	Price
J7E	White	£1568	J9E	White	£1898

# FENICE

Scoop Ice Cream Display



**NEW**



## Features and Benefits

- Fully Automatic Operation
- Electronically Controlled
- Interior Light
- Accepts 5 Litre Napoli Pans (Not Supplied)
- High Storage Capacity (Understorage)
- Fitted Castors
- Scoop Wash Needs Water & Waste Connection (optional part)
- Adjustable Temperature

## Technical Specifications

Temperature Range	-18°C
Refrigerant	R507
Type of Defrost	Electric
No of Bins on Display	
FENICE 103	6
FENICE 118	7
Exterior Finish	White
Interior Finish	Painted Steel
Power Required	13 Amp Supply

External Dimensions	Height:	Width:	Depth:	Capacity:	Weight:
FENICE 103	1165mm	1164mm	702mm	6x 5ltr Pans	120kg
FENICE 118	1165mm	1314mm	702mm	7x 5ltr Pans	136kg

MODEL	Description	Price	MODEL	Description	Price
FENICE 103	White	£1420	FENICE 118	White	£1520

# EDERA

Scoop Ice Cream Display



**NEW**

## Features and Benefits

- Fully Automatic Operation
- Electronically Controlled
- Accepts 5 Litre Napoli Pans (Not Supplied)
- High Storage Capacity (Understorage)
- Fitted Castors

## Technical Specifications

Temperature Range	-18°C
Refrigerant	R507
Type of Defrost	Electric
No of Bins on Display	
Edera 126	10
Edera 157	13
Maximum No of Pans in Under Storage	
Edera 126	10
Edera 157	16
Exterior Finish	White
Interior Finish	Coated Steel
Power Required	13 Amp Supply

EDERA 126

EDERA 157

External Dimensions	Height:	Width:	Depth:	Capacity:	Weight:
EDERA 126	1274mm	1420mm	860mm	10x 5ltr Pans	170kg
EDERA 157	1274mm	1770mm	860mm	13x 5ltr Pans	235kg



MODEL	Description	Price	MODEL	Description	Price
EDERA 126	White	<b>ORDER</b> £2440	EDERA 157	White	<b>ORDER</b> £2560

**FSF350**  
Split Level Display Freezer

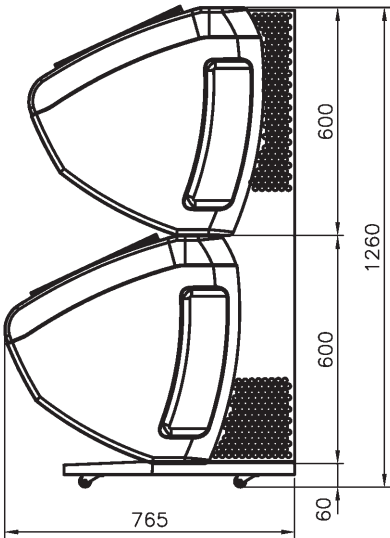

**NEW**



**Technical Specifications**

Temperature Range	-18/-22°C
Refrigerant	R134A
Defrost Type	Manual
Exterior Finish	White/Blue
Interior Finish	Aluminium
Power Required	13 Amp Supply

**Features and Benefits**

- Anti Condensation Single Glazed Lids
- Digital Temperature Display
- Bumper Bars as Standard
- Fan Cooled Condenser
- Heated Sliding Lids
- Illuminated Canopies
- Switchable Interior Light
- Fitted Castors
- Internal Dividers (POA)
- Adjustable Temperature

External Dimensions	Height:	Width:	Depth:	Capacity:	Weight:
FSF350 (Including castors)	1260mm	1200mm	765mm	340ltr (12.0cu.ft.)	48kg

MODEL	Description	Price
FSF350	White	<b>£1680</b>



# CARISMA

Forced Air Scoop Ice Cream Display

ICE CREAM  
DISPLAY



Carisma 7

Carisma 6

Carisma 6+6 115kg

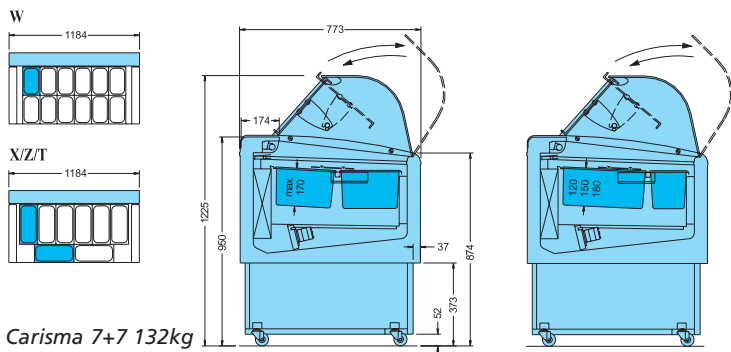

Carisma 7+7 132kg

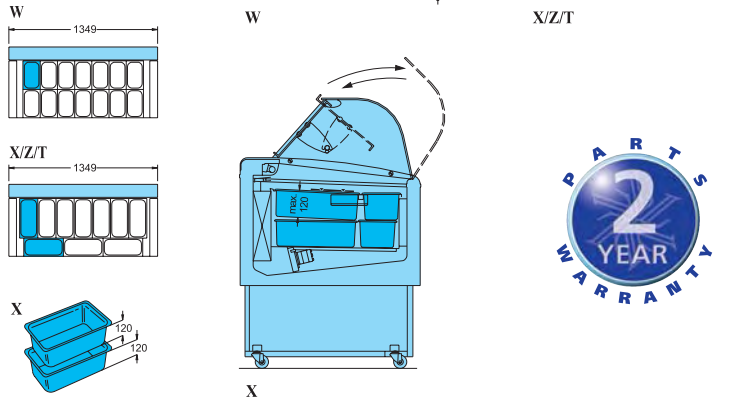

### Features and Benefits

- Hinged Tiltable Curved Front Glass for easy cleaning
- Fully Automatic Operation
- Electronically Controlled
- Interior Light
- Accepts 4 or 5 Litre Napoli Pans (Not Supplied)
- Stainless Steel Interior
- Fitted Castors
- Optional Scoop Wash Needs Water and Waste Connections
- Fan Assisted Cooling

### Technical Specifications

Temperature Range	-15/-18°C
Refrigerant	R404A
Type of Defrost	Auto
No of Bins on Display	
Carisma 6	12x4 ltr or 8x5 ltr Pans
Carisma 7	14x4 ltr or 10x5 ltr Pans
Exterior Finish	White/Green
Interior Finish	Stainless Steel
Power Required	13 Amp Supply

MODEL	Description	Price	MODEL	Description	Price
CARISMA 6	White/Green	<b>ORDER</b> £2834	CARISMA 7	White/Green	<b>ORDER</b> £2882

# GRAN GALA RANGE

Forced Air Scoop Ice Cream Display



## Features and Benefits

- Interior Light
- Accepts 5 Litre Napoli Pans (Not Supplied)
- Fan Assisted Cooling
- Scoop Wash Fitted Needs Water and Waste Connection
- Fitted Castors
- Anti Fogging System for Front Curved Glass (Fan Assist)
- Stainless Steel Interior
- Rear Night Blind
- Electrically Controlled
- Digital Temperature Display
- Fully Automatic Operation
- Polished S/Steel Rear Shelf and Back

## Technical Specifications

Temperature Range	-15/-18°C
Refrigerant	R404A
Type of Defrost	Auto
No of Bins on Display-	
Gran Gala 12	12 x 5 Litre
Gran Gala 16	16 x 5 Litre
Gran Gala 18	18 x 5 Litre
Gran Gala 20	20 x 5 Litre
Gran Gala 24	24 x 5 Litre
Exterior Finish	Blue/Red/Green
Interior Finish	White S/Steel
Power Required	13 Amp Supply for models 12 & 16 20 Amp Supply for models 18, 20 & 24

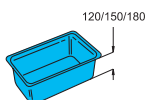

Gran Gala 12 - 260kg XIZIT

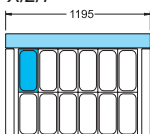

Gran Gala 16 - 315kg XIZIT

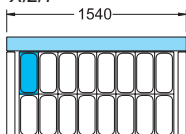

Gran Gala 18 - 340kg XIZIT

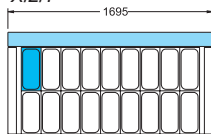

Gran Gala 20 - 370kg XIZIT

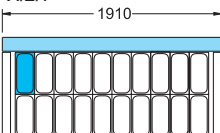

Gran Gala 24 - 450kg XIZIT

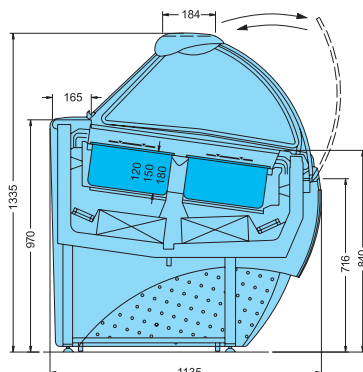
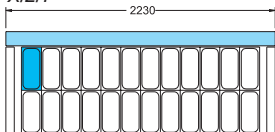

Night Blind in use



Fitted Castors



Scoop Wash

MODEL	Description	Price	MODEL	Description	Price
GRAN GALA 12	Blue/Red/Green	£6715	GRAN GALA 18	Blue/Red/Green	£8108
GRAN GALA 16	Blue/Red/Green	£8065	GRAN GALA 20	Blue/Red/Green	£8672
			GRAN GALA 24	Blue/Red/Green	£9298