

Water Refrigerators

TAEvo 015÷161



MAINTENANCE AND OPERATING MANUAL

Water Refrigerators



CHAPTER 1

QUICK GUIDE

(for further information please consult Chapter 8 “Electronic control“)

1.1 Unit on or off



To turn on and switch off the unit press the  for more than 5 seconds.

NOTE



The temperature regulation of the machine is set by the temperature of the outlet water, which is pointed out by the BTOWT probe.

1.2 Operating principle

1.3 How to modify the set-point and the differential



Press + for more than 5 seconds.



The indication of “00” will appear on the display.



Use  and  buttons to set the value of password, see 8.11.1 “Access for displaying, modifying and setting parameters”

Press  to confirm the password.

The display will show the code of the first available parameter.

Press the buttons  or  to visualize the Set-Point (r01) or the Differential (r02).

The further pressure of  allows to display the selected parameter value, and the eventually modifying by means of  and  buttons.

The pressure of  button stores the new value of the modified parameters and permits to exit from the procedure, while  button allows to return to the parameter selecting menu.

On setting the parameters, the display will automatically flash after a few seconds if no buttons are pressed.

If no button has been pressed after 60 seconds from the procedure activation, the unit will return to normal operation without storing the values of the eventually modified parameters.

ATTENTION

A Setpoint which is too low may cause ice formation so that antifreeze must be added.

Generally the differential values must not be too low. If the differential value must be modified, consider also the delays for compressor starts and stops.

1.4 Control parameters

ATTENTION

The outlet water temperature (Set Point) is usually set as follow.

r01 = SETPOINT CHILLER [°C]	r02 = DIFFERENTIAL [°C]
07.0	04.0



ATTENTION

To modify the SET-POINT CHILLER under the minimum temperature limit of chiller mode (5°C) ask for information to a service center.

1.5 Alarm's masks

Any time an alarm condition is detected, the controller will prompt the following actions:

- the buzzer sounds (if previously enabled, see P4 parameter and if the machine is not in stand-by)
- the alarm relay is activated
- the temperature value flashes on display
- the alarm code appears on the display alternatively with the temperature value

After the alarms have been cleared either with automatic reset or by pressing  and  buttons simultaneously for 5 seconds (for alarms with manual reset), the following actions will occur:

- the buzzer silences
- the alarm relay de-energises
- the temperature value stops flashing
- the alarm code disappears from the display

If the alarm condition persists, the actions described above will be performed again.

The control board allows to detect contemporaneously also more alarm signalings.

After reading the alarm message on the display, use the alarms list (vedi Chapter 10 “Alarm and signalling“) to recognize the alarm and have more information.



INDEX

QUICK GUIDE	1
1.1 Unit on or off.....	1
1.2 Operating principle.....	1
1.3 How to modify the set-point and the differential.....	1
1.4 Control parameters.....	1
1.5 Alarm's masks.....	1
INDEX	3
GENERAL INFORMATION	5
2.1 How to interpret the model.....	6
SAFETY	7
3.1 General.....	7
3.2 General precautions.....	7
3.2.1 Liquids of the user circuit.....	7
3.2.2 Lifting and carriage precautions.....	7
3.2.3 Installation precautions.....	8
3.2.4 Precautions during operation.....	8
3.2.5 Maintenance and repair precautions.....	8
3.3 Refrigerant gases.....	9
3.3.1 Refrigerant safety schedule.....	9
TECHNICAL DATA	11
DESCRIPTION	13
5.1 Operating principle.....	13
5.2 Materials.....	13
5.2.1 Compressors.....	13
5.2.2 Condenser.....	13
5.2.3 Pump.....	13
5.2.4 Fan/s.....	13
5.2.5 Casing.....	13
5.2.6 Materials in contact with the liquid to be cooled.....	14
5.3 Overall dimensions.....	14
5.4 Minimum distances from walls in the installation ambient.....	14
5.5 Water and refrigerant circuits.....	14
5.5.1 Water circuit.....	14
5.5.2 Refrigerant circuit.....	14
5.6 Electrical circuit.....	14
INSTALLATION	15
6.1 Inspection.....	15
6.2 Positioning.....	15
6.3 Antifreeze protection.....	15
6.4 Plumbing connections.....	16
6.5 Expansion tank.....	17
6.6 Electrical connections.....	17
START UP	19
ELECTRONIC CONTROL	21
8.1 Introduction.....	21
8.2 User interface.....	21
8.3 Display.....	21
8.3.1 Information about the status of the unit.....	22
8.3.2 Keypad.....	22
8.3.3 Functions of the buttons.....	22
8.3.4 Putting the unit in stand-by.....	23
8.4 Unit water outlet temperature (BTOWT).....	23
8.5 Evaporator water outlet temperature (BEWOT).....	23
8.6 Circulation pump.....	23
8.7 Remote control.....	23
8.7.1 Simple remote control.....	23
8.7.2 Supervisory network.....	23
8.8 General alarm relay.....	23
8.9 Automatic re-start.....	24
8.10 Structure of the menus.....	24

8.11	Parameters	25
	8.11.1 Access for displaying, modifying and setting parameters	25
PARAMETER TABLES		27
9.1	Parameters related to the unit	27
9.2	Parameters related to the type of probes	28
9.3	Probe reading parameters	28
9.4	Parameters related to the compressor	28
9.5	Regulation parameters	30
9.6	Fan operation parameters	31
9.7	Antifreeze protection and resistance control parameters	32
	9.7.1 Antifreeze function tripping logic	33
9.8	Alarm setting parameters	33
9.9	Defrost parameters	34
ALARM AND SIGNALLING		35
10.1	Buzzer silencing (if it is present)	35
10.2	Alarms reset	35
10.3	Hour-counter zero setting	35
10.4	Alarm and signalling table	35
COMPONENTS SETTING		39
11.1	High and low pressure switches	39
11.2	Level sensor	40
OPERATION AND MAINTENANCE		41
12.1	Operation	41
12.2	Maintenance	41
	12.2.1 Unit access	41
	12.2.2 Water circuit emptying	42
12.3	Maintenance schedule	42
TROUBLE SHOOTING		45

CHAPTER 2

GENERAL INFORMATION

The machines described in this manual are called “WATER REFRIGERATORS” or simply “REFRIGERATORS”.

This manual is written for those responsible for the installation, use and maintenance of the unit.

The components used are of high quality and all the projecting process, from the production to the unit checking, has been manufactured in conformity with ISO 9001 norms.

In most applications, the liquid of the user circuit is water and the term “WATER” will be used even if the liquid of the user circuit is different from water (e.g. a mixture of water and glycol).

Here below the term “PRESSURE” will be used to indicate the gauge pressure.

The following symbols are shown on the stickers on the unit as well as on the overall dimension drawing and refrigeration circuits in this manual.

Their meaning is the following:











	Water inlet in the machine
	Water outlet from the machine
	Indications for lifting the unit
	Water drainage point from the machine
	Electric shock risk
	Thermal exchanging air flow (for air-cooled units)
	Direction of the refrigerant gas flow and water circuit
	Direction of pump rotation (if installed) and of fan rotation
	Water filling point
	Air vent

Table 1 SYMBOLS



2.1 How to interpret the model

MODEL	DESCRIPTION
TAEevo <u>XX</u> X	
	indicative power of the refrigerator compressor in hp
	E = hermetic type compressor
	A = condenser cooled by air
	T = "tank"; refrigerator with accumulator tank.

ATTENTION

This manual provides the user, installer and maintenance technician with all the technical information required for installation, operation and carrying out routine maintenance operations to ensure long life.

If spare parts are required, this must be original.

Requests for SPARE PARTS and for any INFORMATION concerning the unit must be sent to the distributor or to the nearest service centre, providing the MODEL and MACHINE NUMBER shown on the machine data plate and on the first page of this manual.

CHAPTER 3

SAFETY

This machinery was designed to be safe in the use for which it was planned provided that it is installed, started up and maintained in accordance with the instructions contained in this manual.

The manual must therefore be studied by all those who want to install, use or maintain the unit.

The machine contains electrical components which operate at the line voltage, and also moving parts as fans and/or pump.

It must therefore be isolated from the electricity supply network before being opened.

All maintenance operations which require access to the machinery must be carried out by expert or appropriately trained persons who have a perfect knowledge of the necessary precautions.

Avoid the presence of children in the unit installation place.

3.1 General

When handling or maintaining the unit and all auxiliary equipment, the personnel must operate with care observing all instructions concerning health and safety at installation site.

Most accidents which occur during the operation and maintenance of the machinery are a result of failure to observe basic safety rules or precautions.

An accident can often be avoided by recognising a situation that is potentially hazardous.

The user should make sure that all personnel concerned with operation and maintenance of the unit and all auxiliary equipment have read and understood all warnings, cautions, prohibitions and notes written in this manual as well as on the unit.

Improper operation or maintenance of the unit and auxiliary equipment could be dangerous and result in an accident causing injury or death.

Do not operate the unit and auxiliary equipment until the instructions in the Operating section of this manual are understood by all personnel concerned.

Do not carry out any servicing, repair or maintenance work on the unit and auxiliary equipment until the instructions in the relevant sections of this manual are clearly understood by all personnel concerned.

We cannot anticipate every possible circumstance which might represent a potential hazard.

The warnings in this manual are therefore not all-inclusive.

If the user employs an operating procedure, an item of equipment or a method of working which is not specifically recommended, he must ensure that the unit and auxiliary equipment will not be damaged or made unsafe and that there is no risk to persons or property.

3.2 General precautions

3.2.1 Liquids of the user circuit

The liquids of the user circuit must be compatible with the materials used in the hydraulic circuit.

These can be water or mixtures of water and glycol, for example.

The addition of anti-corrosive chemical additives and operating in a pH range between 7 and 8 is recommended.

Even in the case of glycol mixtures, the use of appropriate chemical additives (consult the glycol supplier) is very important to protect the refrigerator materials from possible corrosion caused by the chemical degradation to which glycol is subject.

If the liquids of the user circuit contains dangerous substances (e.g. ethylene glycol) is very important to collect any liquid which leaks because it could cause damages to the ambient.

Furthermore, when the refrigerator is no longer used, dangerous liquids must be disposed of by firms specialised and authorised for treating them.

3.2.2 Lifting and carriage precautions

Avoid injury by using a hoist to lift heavy loads.

Check all chains, hooks, shackles and slings are in good condition and are of the correct capacity.

They must be tested and approved according to local safety regulations.

Cables, chains or ropes must never be applied directly to lifting eyes.

Always use an appropriate shackle or hook properly positioned.

Arrange lifting cables so that there are no sharp bends.

Use a spreader bar to avoid side loads on hooks, eyes and shackles.

When a load is on a hoist stay clear of the danger area beneath and around it.

Keep lifting acceleration and speed within safe limits and never leave a load hanging on a hoist for longer than is necessary.

The handling of units equipped with pallet can be done using fork-lift trucks in accordance with the drawing below.

TAEvo 015-161

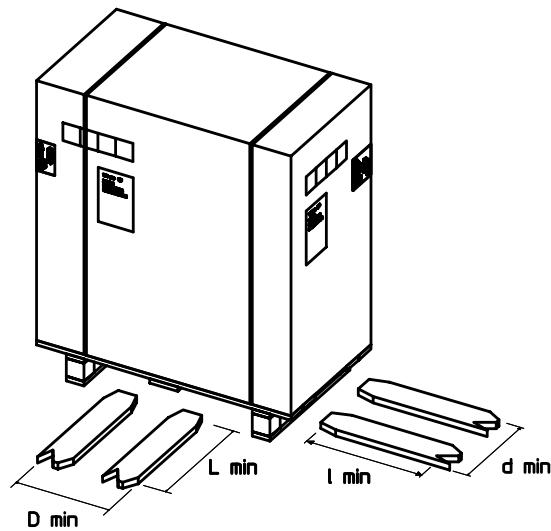

MODEL	l min	d min	L min	D min
TAEevo 015÷020	1000	450	600	600
TAEevo 031÷051	1100	550	800	650
TAEevo 081÷161	1200	650		1000

To calculate the handling efforts, please refer to the weights indicated in the following table:

TAEevo Model	Pointing weight of the units with accumulation group without water [kg]
015	127
020	132
031	200
051	220
081	331
101	386
121	405
161	416

Table 2 WEIGHTS OF THE UNIT

3.2.3 Installation precautions

For the connection to the electrical net see Chapter 6 “Installation“.

3.2.4 Precautions during operation

Operation must be carried out by competent personnel under a qualified supervisor.

All the water piping must be painted or clearly marked in accordance with local safety regulations in the place of installation.

Never remove or tamper with the safety devices, guards or insulation materials fitted to the unit or auxiliary equipment.

All electrical connections must comply with local codes.

The unit and auxiliary equipment must be earthen and protected by fuses against short-circuits and overloading.

When mains power is switched on, lethal voltages are present in the electrical circuits and extreme caution must be exercised whenever it is necessary to carry out any work on the electrical system.

Do not open any electrical panels or cabinets or touch any electrical components or associated equipment while voltage is applied unless it is necessary for measurements, tests or adjustments.

Such work should be carried out only by a qualified electrician equipped with the proper tools and wearing appropriate body protection against electrical hazards.

3.2.5 Maintenance and repair precautions

Maintenance, overhaul and repair work must be carried out by competent personnel under a qualified supervisor.

When disposing of parts and waste material of any kind make sure that there is no pollution of any drain or natural water-course and that no burning of waste takes place which could cause pollution of the air.

- Protect the environment by using only approved methods of disposal.
- If replacement parts are needed use only original spares.
- Keep a written record of all maintenance and repair work carried out on the unit and auxiliary equipment.
- The frequency and the nature of the work required over a period can reveal adverse operating conditions which should be corrected.
- Use only refrigerant gas specified on the specification plate of the unit.
- Make sure that all instructions concerning operation and maintenance are strictly followed and that the complete unit, with all accessories and safety devices, is kept in good working order.
- The accuracy of pressure and temperature gauges must be regularly checked.
- They must be renewed when acceptable tolerances are exceeded.
- Keep the machine clean at all times.
- Protect components and exposed openings by covering them, for example, with clean cloth or tape during maintenance and repair work.
- Do not weld or carry out any operation which produces heat near a system which contains oil or flammable liquids.
- The systems which may contain oil or flammable liquids must be completely drained and cleaned (with steam, for example), before carrying out these operations.
- Never weld, nor modify in any way, a vessel which may be put under pressure.
- To prevent an increase in working temperature, inspect and clean heat exchanging surfaces (i.e. condenser fins) regularly. For every unit establish a suitable time schedule for cleaning operations.
- Avoid to damage the pressure relief devices.
- Precautions must be taken when carrying out welding or any repair operation which generates heat, flames or sparks.
- The adjacent components must always be screened with non-flammable material and if the operation is to be carried out near any part of the lubrication system, or close to a component which may contain oil, the system must first be thoroughly purged, preferably by steam cleaning.
- Never use a light source with an open flame to inspect any part of the machine.
- Before dismantling any part of the unit ensure that all heavy movable parts are secured.
- When a repair has been completed, make sure no tools, loose parts or rags are left in, or on the machine.
- Check the direction of rotation of electric motors (the pump if installed) when starting up the unit initially and after any work on the electrical connections or switch gear.
- All guards must be reinstalled after carrying out repair or maintenance work.
- Do not use flammable liquid to clean any component during operation.
- If chlorinated hydrocarbon non-flammable fluids are used for cleaning, safety precautions must be taken against any toxic vapours which may be released.

ATTENTION

- Before removing any panels or dismantling any part of the unit, carry out the following operations:*
- Isolate the unit from the main electrical power supply by disconnecting the cable from the electrical power source.
 - Lock the isolator in the "OFF" position with a lock.
 - Attach a warning label to the main isolator switch conveying: "WORK IN PROGRESS - DON NOT APPLY VOLTAGE".
 - Do not switch on electrical power or attempt to start the unit if a warning label is attached.

3.3 Refrigerant gases

These units can use R407c or R22
 Never attempt to mix refrigerant gases.
 To clean out a very heavily contaminated refrigerant system, e.g. after a refrigerant compressor burnout, a qualified refrigeration engineer must be consulted to carry out the task.
 The manufacturer's instructions and local safety regulations should always be observed when handling and storing high pressure gas cylinders.

3.3.1 Refrigerant safety schedule

	R407C	R22
Denomination:	23% Difluoromethane (R32); 25% Pentafluoroethane (R125); 52% R134a	chlorodifluoromethane
INDICATION OF THE DANGERS		
Major dangers:		Asphyxia
Specific dangers:	Rapid evaporation can cause freezing	Unknown
FIRST AID MEASURES		
General information:	Do not give anything to unconscious persons	
Inhalation:	Take the person outdoors. Use oxygen or artificial respiration if necessary. Do not administer adrenaline or similar substances	
Contact with the eyes:	Thoroughly wash with plenty of water for at least 15 minutes and call a doctor	

Table 3 SAFETY SCHEDULE R407C AND R22



Contact with the skin:	Wash immediately with plenty of water. Remove contaminated clothing immediately	
FIRE-FIGHTING MEASURES		
Means of extinction:	Any means	
Specific dangers:	Pressure increase	
Specific methods:	Cool the containers with water sprays	
MEASURES IN THE EVENT OF ACCIDENTAL LEAKAGE		
Individual precautions:	Evacuate personnel to safe areas. Provide adequate ventilation. Use means of personal protection	
Environmental precautions:	Evaporates	
Cleaning methods:	Evaporates	
HANDLING AND STORAGE		
Handling technical measures/ precautions:	Ensure sufficient air change and/or extraction in the work areas	Only use in well-aired premises
recommendations for safe use:	Do not inhale vapours or aerosols	
Storage:	Close properly and store in a cool, dry well-ventilated place. Store in its original containers. Incompatible products: explosives, flammable materials, organic peroxide	Close properly and store in a cool, dry well-ventilated place
CONTROL OF EXPOSURE/INDIVIDUAL PROTECTION		
Control parameters:	AEL (8-h e 12-h TWA) = 1000 ml/m ³ for each of the three components	1000 ppm v/v or ml/m ³ = 3540 mg/m ³ as weighted average over 8 hours
Respiratory protection:	For rescue and maintenance work in tanks, use autonomous breathing apparatus. The vapours are heavier than air and can cause suffocation, reducing the oxygen available for breathing	
Protection of the eyes:	Safety goggles	
Protection of the hands:	Rubber gloves	
Hygiene measures:	Do not smoke	
PHYSICAL AND CHEMICAL PROPERTIES		
Colour:	Colourless	
Odour:	Similar to ether	
Boiling point:	-43.9°C at atm. press.	-40.8°C at atm. press.
Flammability point:	Non flammable	
Relative density:	1.138 kg/l at 25°C.	1.194 kg/l at 25°C.
Solubility in water:	Negligible	3 g/l at 25°C at atm. press.
STABILITY AND REACTIVITY		
Stability:	No reactivity if used with the relative instructions	
Materials to avoid:	Alkaline metal, earthy alkaline metals, granulated metals salts, Al, Zn, Be, etc. in powder	
Hazardous decomposition products:	Halogen acids, traces of carbonyl halides	
TOXICOLOGICAL INFORMATION		
Acute toxicity:	(R32) LC50/inhalation/4 hours/lab. rats >760 ml/l (R125) LC50/inhalation/4 hours/lab. rats >3480 mg/l (R134a) ALC/inhalation/4 hours/lab. rats = 567 ml/l	LC50/inhalation/4 hours/lab. rats = 220 ml/l
Local effects:	Concentrations substantially above the TLV can cause narcotic effects. Inhalation of products in decomposition can lead to respiratory difficulty (pulmonary oedema)	Concentrations substantially above 1000 ppm v/v can cause narcotic effects. Inhalation of products in decomposition can lead to respiratory difficulty (pulmonary oedema)
Long-term toxicity:	Has not shown any cancerogenic, teratogenic or mutagenic effects in experiments on animals	
ECOLOGICAL INFORMATION		
Global warming potential HGWP (R11=1):	R125: 0.84 - R134a: 0.28	0.098
Ozone depletion potential ODP (R11=1):	0	0.05
CONSIDERATIONS ON DISPOSAL		
Usable with reconditioning		

Table 3 SAFETY SCHEDULE R407C AND R22

CHAPTER 4

TECHNICAL DATA

The main technical data are given on the machine data plate:

MODEL and CODE	They identify the size of the unit and the type of construction.
MANUAL	This is the code number of the manual.
SERIAL NUMBER	This is the construction number of the unit.
MANUFACTURING YEAR	This is the year of the final test of the unit.
VOLTAGE/PHASE/FREQUENCY	Electric alimentation characteristics.
MAX. CONSUMPTION (I max)	This is electrical current consumed by the unit during the limit working conditions (refrigerant condensing temperature is 65°C = 149°F; refrigerant evaporating temperature is 10°C = 50°F).
INSTALLED POWER (P max)	It is the power absorbed by the unit during the limit working conditions (refrigerant condensing temperature is 65°C = 149°F; refrigerant evaporating temperature is 10°C = 50°F).
PROTECTION	As defined by the EN 60529 European standard.
REFRIGERANT	This is the refrigerant fluid in the unit.
REFRIGERANT QUANTITY	This is the quantity of refrigerant fluid contained in the unit.
MAX. COOLING PRESSURE	This is the design pressure of the refrigeration circuit.
MAX. COOLING TEMPERATURE	This is the design temperature of the refrigeration circuit.
USER CIRCUIT FLUID	Fluid used by the unit (normally water).
MAX. COOLING PRESSURE	Max. design pressure of the user circuit.
MAX. TEMPERATURE	Design temperature of the user circuit; this should not be confused with the maximum working temperature which is established when the offer is made.
CONDENSER COOLING FLUID	Fluid used by the unit to cool the condenser (this data is not present if the unit is air cooled condensed).
MAX. COOLING PRESSURE	Max. design pressure of the condenser cooling circuit (this data is not present if the unit is air cooled condensed).
MAX. TEMPERATURE	Max. design temperature of the condenser cooling circuit (this data is not present if the unit is) air cooled condensed).
SOUND PRESSURE LEVEL	Sound pressure level in free field in hemispheric irradiation conditions (open field) at a distance of 1 m from the unit, condenser side, and at a distance of 1.2 m from the ground.
AMBIENT TEMPERATURE	Min. and max. cooling air temperature value.
WEIGHT	This is the approximate weight of the unit before packing.

Table 4 DATA PLATE AND MEANING OF ABBREVIATIONS

On the wiring diagram you will find the following abbreviations (see the first column in the table above):

IMAX	max. electric current;
PMAX	max. power;
ILR	electric current with rotor stopped;

ATTENTION

The performance of the unit depends principally on the water flow rate and temperature of the user circuit and on the temperature of the condenser thermal exchanging fluid.

These data are defined in the offer and it is to these that reference should be made.

Other data relative to the standard machines:

Model			015	020	031	051
Tank capacity	water volume	(litres)	60	60	115	115
PUMP P3	water flow rate	(m ³ /h)	0.9/4.8	1.2/4.8	1.7/6	2.5/6
	available head	(bar)	3/2	2.9/2	3/2.1	2.9/2.1
	absorbed power	(kW)	0.55	0.55	0.75	0.75
PUMP P5	water flow rate	(m ³ /h)	0.93/4.8	1.22/4.8	1.7/4.8	2.6/4.8
	available head	(bar)	5.5/3.7	5.5/3.7	5.3/3.7	5.1/3.8
	absorbed power	(kW)	1.1	1.1	1.1	1.1
Axial fan	number of fans		1	1	1	1
	complete air flow	(m ³ /h)	4050	3500	6900	6400
Centrifugal fan	number of fans		--	--	1	1
	available head	(Pa)	--	--	166	185
	complete air flow	(m ³ /h)	--	--	6900	6400

Table 5 CHARACTERISTICS OF STANDARD UNITS

Model			081	101	121	161
Tank capacity	water volume	(litres)	140	255	255	255
PUMP P3	water flow rate	(m ³ /h)	3.5/9.6	5.1/9.6	6.1/18	7/18
	available head	(bar)	2.8/1.7	2.6/1.7	2.9/2.2	2.85/2.2
	absorbed power	(kW)	0.9	0.9	1.85	1.85
PUMP P5	water flow rate	(m ³ /h)	3.6/13	5.2/13	6.15/13	7/13
	available head	(bar)	5.2/3.6	5/3.6	4.9/3.6	4.7/3.6
	absorbed power	(kW)	2.2	2.2	2.2	2.2
Axial fan	number of fans		2	2	2	2
	complete air flow	(m ³ /h)	9200	16000	15000	14200
Centrifugal fan	number of fans		2	2	2	2
	available head	(Pa)	260	140	125	138
	complete air flow	(m ³ /h)	9200	13600	13500	12780

Table 6 CHARACTERISTICS OF STANDARD UNITS

NOTE

- The head is the head available to the user.
- It is possible for the pump installed to be different from the standard. In this case reference should be made to the data in the offer.
- Two numbers are given for the flow rate and the head of each model and of each pump; the first number refers to the nominal conditions while the second refers to the maximum conditions.

CHAPTER 5

DESCRIPTION

5.1 Operating principle

All the units described in this manual work on the basis of the same principle.

A refrigerant circuit cools the surfaces of a tube plate evaporator which finds inside a tank where the liquid to be cooled flows.

The refrigerant compressor is controlled by an electronic control unit which controls the water outlet temperature from the unit in order to maintain it within the preset limits.

5.2 Materials

The data relating to the materials refer to standard machines.

In case of particular units special materials are used, so it is necessary to refer to the data on the offer.

5.2.1 Compressors

The compressors are of hermetic type with single pistons until TAEevo 051, and of single scroll hermetic type from model TAEevo 081 to 161.

These components find inside a closed compressor's compartment, easily accessible.

5.2.2 Condenser

Consisting of a fin-pack battery with aluminium fins, copper tubes and shoulders in galvanised sheet.

The condenser batteries have been calculated, dimensioned and designed by means of modern computerised design technics.

A good subcooling completes the total efficiency increasing the unit final COP (Coefficient Of Performance = cooling capacity/absorbed power).

5.2.3 Pump

The pumps P3 version (3 bar) and P5 version (5 bar) are in stainless steel.

5.2.4 Fan/s

Axial fans

The fans of axial type consist of a die-cast aluminium fan with sickle profile.

The protection rating of the fans is IP54.

All fans have "F" insulation class to assure the external working with all types of climates.

The assembly is completed with a superior (support to the fan) safety protection grill.

Centrifugal fans

The centrifugal fans are of double sucking type with propeller directly mortised to the motor shaft

5.2.5 Casing

The whole base, risers, panels are in galvanised carbon steel sheet fixed together with screws.

All the sheets are phospho-degreasing treated and painted with polyester-powders.

The structure has been designed for the easy access to all the unit components.

5.2.6 Materials in contact with the liquid to be cooled

The materials in contact with the liquid to be cooled can belong to two different groups:

Standard refrigerators: carbon steel, copper, aluminium, zinc, brass, stainless steel and plastics in particular:

- evaporator with copper tubes, aluminium fins and shoulders in galvanised steel;
- tank in carbon steel;

Refrigerators with non-ferrous water circuit: stainless steel (AISI 304), copper, brass and plastics in particular:

- evaporator with tubes and fins in copper and brass shoulders;
- tank in AISI 304 stainless steel; if coupled with stainless steel pumps, the fittings and piping will also be in non-ferrous materials (stainless steel and/or brass and/or plastics).

5.3 Overall dimensions

See enclosures.

5.4 Minimum distances from walls in the installation ambient

See enclosures.

5.5 Water and refrigerant circuits

See enclosures.

5.5.1 Water circuit

The water circuit consists of a tank inside which is a fin-pack heat exchanger. The water passes through the pack, remaining in contact with the fins and is cooled by the refrigerant fluid which evaporates inside the tubes. The cooled water is sucked by a centrifugal pump which sends it directly to the user. The pump delivery is connected to the tank inlet using a by-pass piping which guarantees a minimum water flow through the evaporator in the event a pipe at unit inlet or outlet be closed by mistake. A water pressure gauge is connected to the pump output and is located on the rear panel of the machine, it indicates the water pressure at the plant output and the pressure at plant refilling (with pump stopped).

Furthermore, TAEevo units are furnished with a level sensor (see Chapter 11 "Level sensor").

5.5.2 Refrigerant circuit

The refrigerant is pumped by the hermetic refrigerant compressor to a condenser.

The condenser is a fin-pack type heat exchanger with copper tubes and is cooled by an air-flow produced by one or more power fans, according to the unit's model.

The power fan(s) of the condenser is/are controlled by a pressure switch according to the condensation pressure.

After the condenser, the refrigerant liquid passes through:

- a drying filter,
- a flow indicator,
- a thermostatic valve.

The refrigerant then enters the evaporator, of finned coil type, inside the tank.

When it exits the evaporator, the refrigerant is again sucked by the compressor and the cycle repeats itself.

5.6 Electrical circuit

See enclosures.

INSTALLATION

ATTENTION

Before carrying out the installation or operating on this machine, ensure that all the personnel has read and understood the Chapter 3 "Safety".

ATTENTION

Do not canalize the cooling air, because this reduces the performance of the machine, as regard the max ambient temperature and the cooling efficiency.

6.1 Inspection

Immediately after uncrating, inspect the unit.

6.2 Positioning

1. The unit may be installed both outdoors and indoors.
2. If installed indoors, the room must be well ventilated and with a sufficient height which allows the air to be expelled by fans. In some cases it may be necessary to install fans or extractors to limit the temperature of the room.
3. The ambient air must be clean and not contain flammable gas or solvents.
The minimum and maximum working ambient temperature are specified on the unit data plate. In extreme temperature conditions, the protection devices may trip.
4. The machine must be positioned on any flat surface capable of supporting its weight.
5. Leave at least one metre around the unit to permit access during service operations.
6. Do not obstruct or disturb the condenser's flow of thermal exchanging air.
Position the unit in such a way that the thermal exchanging air cannot recirculate in the intake grilles.

6.3 Antifreeze protection

Even if the minimum working temperature is above 0°C it is possible for the machine - during stoppages in the cold seasons - to find itself in an environment with a temperature below 0°C.

In these cases, if the machine is not emptied, antifreeze (ethylene glycol) must be added in the following percentages to prevent the formation of ice:

Min. ambient temp. [°C]	Ethylene glycol [% in volume]
<0	10
-5	15
-10	20
-15	30
-20	35

Table 7 ADDITION OF ETHYLENE GLYCOL ACCORDING TO THE AMBIENT TEMPERATURE

Add the following anti-freeze (ethylene glycol) percentages in order to avoid freezing when operating at low water outlet temperature:

Water outlet min. temperature [°C]	Ethylene glycol [% in volume]
<5	10
0	15
-5	20
-10	30
-15	35
-19,9	40

Table 8 ADDITION OF ETHYLENE GLYCOL ACCORDING TO THE WATER OUTLET TEMPERATURE



6.4 Plumbing connections

On the back site of the unit there are threaded water connections (see figures) with tubes diameter indicated in the table below.



1. Connect the unit to the water pipelines respecting the water flow direction as indicated in the figures above or in the annexed overall dimension drawings.
2. Provide two cocks (one at the inlet and one at the outlet) for excluding the unit when maintaining without emptying the user water circuit.
3. Fill the tank with water using:
 - a remote refilling system.
 - in this case it is necessary to leak manually the air from the tank by operating on the manual valve*.
 - If there are frequent air infiltrations into the water circuit it is advisable to install an automatic bleed valve.
4. If the unit is without pump, be sure that the pump installed by the user has the aspiration directly connected to the tank suction.

It is recommended to install a water filter to the inlet pipeline in order to avoid solid particles enter in the unit damaging the pumps.

The unobservance of this prescription can be the cause of irreparable damages to the evaporator.

The hydraulic plant must be dimensioned so that the pressure values of the water flow into the unit are not higher than those indicated in the table below:

Model	IN/OUT water connections diameter	Max. pressure [bar] Units with tank
015	Rp 3/4"	6
020	Rp 3/4"	6
031	Rp 1"	6
051	Rp 1"	6
081	Rp 1.1/2"	6
101	Rp 1.1/2"	6
121	Rp 1.1/2"	6
161	Rp 1.1/2"	6

Table 9 WATER CONNECTIONS AND MAX. OPERATING PRESSURE

* Assure (by checking on the pressure gauge the tank pressure with pump stopped) that the pressure into the water circuit is about 0.5 bar to avoid that the pump during its operation puts in depression the tank by causing the possible air entering and however to obstacle the use of manual or automatic air vent systems.



6.5 Expansion tank

If the hydraulic circuit is of closed type, it is necessary to install an expansion tank.

The expansion tank must always be connected at pump inlet.

To calculate the minimum volume of the expansion tank required for a given installation, the formula below can be used and is valid if the pressure is less than or equal to 0.5 bar when the pump is stopped and the maximum working pressure of the expansion tank is greater than or equal to 4 bar.

The volume of the expansion tank V in litres is given by the formula:

$$V = 2 \cdot V_t \cdot (P_{tmin} - P_{tmax})$$

where:

- V_t**= total volume of the circuit in litres
- P_{tmin}**= specific weight at the minimum temperature obtainable by water over the year in °C (even with the plant stopped)
- P_{tmax}**= specific weight at the maximum temperature obtainable by water over the year in °C (even with the plant stopped)

Example of calculation:

V_t=200 litres

percentage of ethylene glycol in volume=30%

t_{min}=5°C from the table **P_{tmin}**=(1.045+1.041)/2 = 1.043

t_{max}=40°C from the table **P_{tmax}**=1.0282

V=2 · 200 · (1.043 - 1.0282)=5.92 litres

Table of specific weights P

	% Glycol	0%	10%	20%	30%	40%
Temperature [°C]	-20	1,0036	1,0195	1,0353	1,0511	1,0669
	-10	1,0024	1,0177	1,033	1,0483	1,0635
	0	1,0008	1,0155	1,0303	1,045	1,0598
	10	0,9988	1,013	1,0272	1,0414	1,0556
	20	0,9964	1,0101	1,0237	1,0374	1,051
	30	0,9936	1,0067	1,0199	1,033	1,0461
	40	0,9905	1,003	1,0156	1,0282	1,0408
	50	0,9869	0,9989	1,011	1,023	1,0351
	60	0,983	0,9945	1,006	1,0175	1,029
	70	0,9786	0,9896	1,0005	1,0115	1,0225

Table 10 SPECIFIC WEIGHTS

6.6 Electrical connections

The connection of the unit to the power supply network must be done in conformity with the laws and prescriptions in force in the installation place.

The power supply voltage, the frequency and the phase number must be as shown on the unit data plate.

The power supply voltage must not be, also for short periods, out of the tolerances given in the wiring diagram.

Except for different indications, the frequency tolerance is +/-1% of the nominal value (+/-2% for short periods).

In the event of three-phase supply, the system must be symmetrical (equal effective voltage values and equal phase angles among consecutive phases).

In particular, except for different indication, the max. unbalance between each phase is 2%. The unbalance is calculated as following:

$$\frac{\text{Max difference of each phase from } V_{avg}}{V_{avg}} \times 100$$

V_{avg}= average of voltage phases

In the event of single-phase supply, check that there is a neutral line in the electrical installation and it is earthen in the transformer cabin (TN system in compliance with IEC 364) or that this is done by the electricity supply company (TT system in compliance with IEC 364).

The phase conductor and the neutral wire must not be confused.

For the electrical supply:

1. connect the unit (PE terminal in the electrical panel) to the earthed system of the building
2. guarantee the automatic interruption of the power supply in the event of insulation failure (protection against indirect contacts in compliance with IEC 364) by means of a differential device (normally with operation nominal current of 0.03 A)
3. at the beginning of the electrical supply cable must be guaranteed a protection against direct contacts with a protection degree of IP2X or IPXXB at least
4. at the beginning of the electrical supply cable must be installed protection devices that protect against overcurrents (short circuit) (see information in the electrical wiring)
5. use conductors which transform the max. current required to the max. operating ambient temperature, according to the selected installation type (IEC 364-5-523) (see information in the electrical wiring)

Indications of electrical wiring:

A max. size permitted for the fuse type gG.

In general, the fuses can be replaced with an automatic switch regulated by means of the unit max. absorbed current (contact the manufacturer if necessary)

B section and type of the power supply cable (if not already supplied):

- installation: insulated conductors, multipolar cable in duct, in air or over masonry (C type in compliance with IEC 364-5-523 1983) or without no other cable in contract
- working temperature: the max. working ambient temperature of the unit
- cable type: copper conductors, PVC insulation from 70°C (if not specified) or EPR insulation from 90°C

START UP

ATTENTION

Before starting up these units be sure that all personnel have read and understood the Chapter 3 "Safety".

1. Check that the machine's on/off valves are open.
2. Check that the tank is completely full of water and properly vented.
3. It is possible to check that the pressure read on the pressure gauge on the machine back panel is about 0.5 bar (only if the hydraulic circuit is of closed type).
4. Check that the ambient temperature is within the limits indicated on the machine data plate (air condensed units).
5. Check that the main switch is in the OFF position ("0").
6. Check that the power supply voltage is correct.
7. Power the machine by means of the supply line protection device.
8. Turn the machine main switch ON ("1").
9. To start the unit, press the button  for more than 5 seconds.
10. In three-phase units check that the compressor works correctly (it must not be noisy or overheated) and check that the pump rotation direction is correct (if installed).
If necessary invert two phases of supply.

NOTE

To avoid damaging the pump it is necessary to increase the pressure drop in the hydraulic circuit: e.g. partially closing a pump outlet cock (cock at pump outlet by installer).

11. Check that the rotation direction of the fan is correct (if there is a pump and it rotates in the correct direction, then so will the fan). The cooling air must enter the refrigerator through the grille next to the condenser. If necessary invert two phases to reverse the rotation direction.
12. Check that the difference in pressure between the reading on the pressure gauge on the machine control panel with the pump running and the pump stopped is greater than the available head with maximum pump delivery. If this difference is lower it means that the water flow rate is greater than the permitted maximum. To avoid damaging the pump it is necessary to increase the pressure drop in the hydraulic circuit: e.g. partially closing a pump output cock.
13. Models with centrifugal fans:
Check that the output of the centrifugal fans is correctly ducted and that the pressure drop of the ducting system is about equal to the available head. If the pressure drops are:
 - greater this means that there is a reduction in the flow of cooling air with a consequent drop in machine performance and the possibility of protection devices tripping even at relatively low ambient temperatures;
 - lower this means that the air flow may be too high for the fan and this could be dangerous for the centrifugal fan motor.
14. If with the first start-up, there is a high ambient temperature and the temperature of the water in the hydraulic circuit is much higher than the working value (e.g. 25-30°C) this means that the refrigerator starts up overloaded with the consequence of possible tripping of the protection devices. To reduce this overload, a refrigerator outlet valve can be gradually (but not totally!) closed to reduce the flow of water passing through it. Open the valve as the water temperature in the hydraulic circuit reaches the working value.
15. The machine is now ready for operation.
If the thermal load is lower than that produced by the unit, the water temperature drops until it reaches the set point ($r \setminus$ parameter) set following the instruction of Chapter 8 "Electronic control".
When $r \setminus$ value has been reached, the thermostat controlling the water outlet temperature stops the compressor.
The water pump continues to run however.



ELECTRONIC CONTROL

8.1 Introduction

The main functions of the electronic control are:

- Control of the unit water outlet temperature;
- Complete management of the alarms;
- Control of the evaporator outlet temperature.

The electronic board can control the following devices:

- Compressor;
- Water circulation pump;
- Alarm signalling devices.

8.2 User interface



8.3 Display



The display consists of 3 digits, with the automatic display of the decimal point between -19.9 and +19.9°C; outside this measurement range, the value is automatically displayed without decimal (although in its inside the machine is always operating by taking into account the decimal part).

ATTENTION

During normal operation, the displayed value corresponds to the temperature read by BTOWT probe, that is the unit water outlet temperature.

8.3.1 Information about the status of the unit

The information about the status of the unit are shown on the display by means of 12 LEDs. Following their meaning:

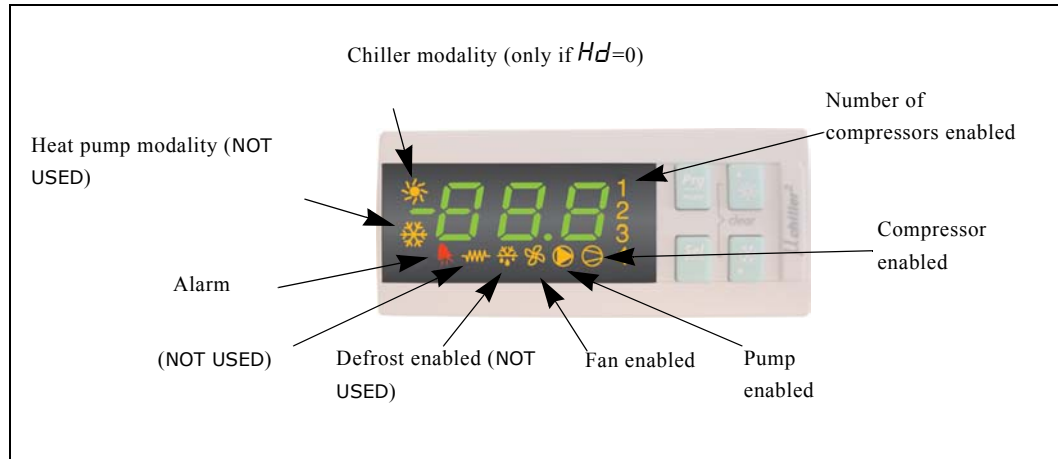

Table 11 LEDs

8.3.2 Keypad

The keypad allows to set the function parameters of the unit.

The meaning of each button is indicated below.

8.3.3 Functions of the buttons

The table below shows the meaning and functions of each button in the various modalities (for further information see 8.11.1 “Access for displaying, modifying and setting parameters”).

• Use of the buttons:

Status of the electronic control	Pressed button	Effect after pressing the button
Normal operating condition	PRG mute	NOT USED
List of parameter codes		stores the parameters in Eeprom and returns to display the temperature measured by BTOWT probe
Displays values		cancels the modification and returns to the main menu
Buzzer sounds		silences the buzzer
Normal operating condition	▲	NOT USED
List of parameter codes		displays the codes of the parameters
Displays values		increases the value
Normal operating condition	▼	NOT USED
List of parameter codes		displays the codes of the parameters
Displays values		decreases the value
Normal operating condition (that is when the display shows the temperature measured by BTOWT probe)	SEL	after 5" DIRECT parameters appear
List of parameter codes		displays value
Displays values		displays list of parameter codes and stores the new parameter

Table 12 USE OF THE BUTTONS



- Use of combined buttons:

Status of the electronic control	Pressed button	Effect after pressing the button
Normal operating condition		after 5" password required for FACTORY parameters
Normal operating condition		after 5" forces a manual defrost cycle (if the temperature/pressure conditions permit it)
Normal operating condition		after 5" manual alarm resetting
Hour-counter displaying		hour counter zeroes down immediately
At start-up (by the main switch)		writing of reset parameters

Table 13 USE OF COMBINED BUTTONS

8.3.4 Putting the unit in stand-by

To put the unit in stand-by, press button for more than 5 seconds.

8.4 Unit water outlet temperature (BTOWT)

The temperature control function of the unit is fixed by the water temperature value exiting the unit which is measured by BTOWT probe.

It is normally displayed when no button is pressed.

In alarm conditions the temperature measured by BTOWT is displayed flashing alternate with the alarm code message.

8.5 Evaporator water outlet temperature (BEWOT)

It is used as antifreeze function to avoid that the water temperature falls and reaches values dangerous for the ice formation.

To display the value measured by BEWOT probe, select the parameter *b02* following the indications of paragraph 8.11 "Parameters".

8.6 Circulation pump

When the machine is turned on (pressing button for more than 5 sec. with power supply protection device in ON position), the pump controlled by KP1 (see wiring diagram) contactor starts and continues to run until the machine is put in stand-by pressing button or is put in OFF by means of the power supply protection device.

If the compressor is also enabled to start, the pump always starts some seconds before it.

The pump only stops with the following alarms:

- pump thermal alarm;
- probe alarm;
- Eeprom alarm.
- pump-fan automatic switch alarm;
- compressor automatic switch alarm;
- level sensor alarm.

8.7 Remote control

8.7.1 Simple remote control

All units can be remote controlled by means of a "clean contact" (in exchange) appropriately connected to the electrical panel (consult the wiring diagram).

To do this, after switching OFF the unit, it is necessary to access the electrical panel (see paragraph 12.2.1 "Unit access") and to find out -X1 connecting terminal.

There are connectors, useful to remote (by means of a cable with orange conductors as indicated in EN 60204-1 point 14.2.4) a contact for the unit switching ON and OFF.

They are indicated by the numbers 2 and 45.

ATTENTION

For the correct operation of the simple remote control don't forget to set parameter $H07=1$.

For further information consult Chapter 9 "Parameter tables".

After switching ON the main switch, if the contact connected to connectors is closed the unit will start, if it is opened the unit will stop. However, it will be possible to switch ON and/or OFF the unit by means of the electronic board, except when the remote control is in OFF position.

8.7.2 Supervisory network

The electronic control of units allows you the possibility to be interfaced to a supervisory network in RS485 standard (asynchronous).

For further information see the μ CHILLER² SUPERVISOR KIT manual, code 381703202.

8.8 General alarm relay

During unit's normal operation (no alarm enabled), at pump starting-up, a clean contact is produced by connectors 42 and 43 on the terminal board -X1.

In the event of power interruption to the unit (the magnetic protection upstream to the electrical plant, main breaker in 0 position, etc...) the circuit between the connectors 42 and 43 is opened.

In the event of an alarm detected by the control board by means of the connectors 42 and 44 on the terminal board -X1, a clean contact is produced.

The maximum flow of the clean contacts is of 8A AC1 250V, furthermore, the connection must be carried out with orange conductors as indicated in EN 60204-1 point 14.2.4.

8.9 Automatic re-start

After a loss of power, the unit will re-start automatically if it was ON, observing the selected operating modality, but not if it was OFF before the loss of power.

8.10 Structure of the menus

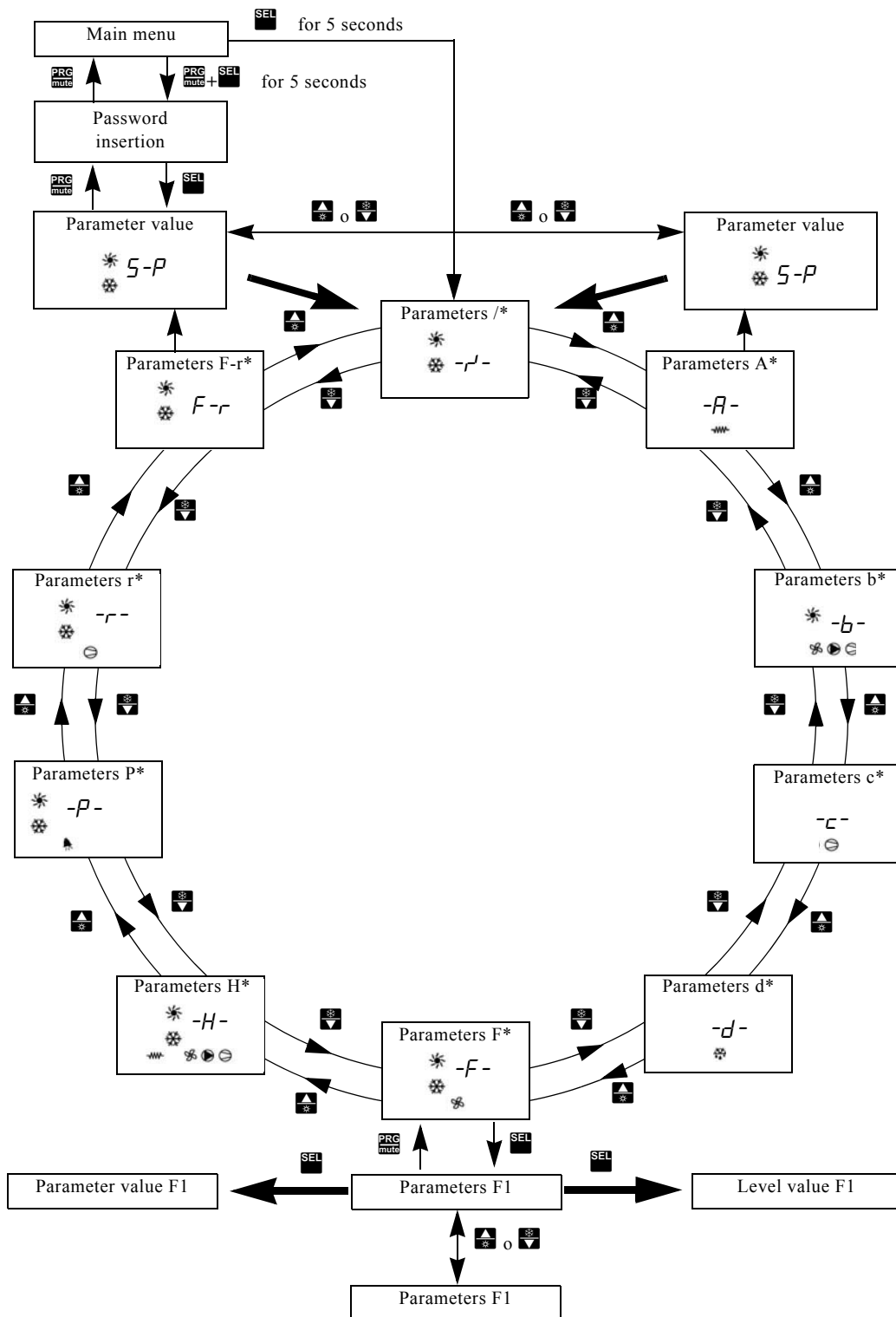

8.11 Parameters

The parameters are divided in 4 types according to their access by the user by means of password and according to their function. In each level it is possible to enable the access to the parameters of the same level by lower levels. In this way, by **FACTORY** password it is possible to set for each parameter the desired level. The parameter are divided in the following 4 types:

DIRECT (D)	These parameters manage the unit regulation and the display of temperatures measured by probes. They are directly accessible without password; it is recommended to call the technical service personnel before modify the setpoint and differential.
USER (U)	These parameters manage the unit operating logic and the alarm tripping logic. They includes all DIRECT parameters. They are accessible via password and must be modify by qualified technical service personnel only.
SUPER USER (S)	These parameters manage the unit operating logic and the alarm tripping logic. They includes all USER and DIRECT parameters. They are accessible via password and must be modify by qualified technical service personnel only.
FACTORY (F)	These parameters are set by the manufacturer to fix the unit configuration. They includes all DIRECT and USER parameters. They are accessible via password and their modification should never be necessary, however it must be made by qualified technical service personnel only.

They can be identified in column "TYPE" of parameter tables.

8.11.1 Access for displaying, modifying and setting parameters

ATTENTION

The modification of operating parameters must be done by technical service personnel only. The observance missing of the manual indications or the not competent manipulation of the operation parameters can be the cause of irreparable damages to the unit components.

DIRECT parameters access

Press **SEL** for more than 5 seconds.
 The display will show the code of the first available parameter.
 The pressure of **▲** and **▼** allows to scroll sequentially all parameters.
 The further pressure of **SEL** allows to display the selected parameter value, and the eventually modifying by means of **▲** and **▼** buttons.
 The pressure of **SEL** button stores the new value of the modified parameters and permits to exit from the procedure, while **PRG** button allows to return to the parameter selecting menu.
 On setting the parameters, the display will automatically flash after a few seconds if no buttons are pressed.
 If no button has been pressed after 60 seconds from the procedure activation, the unit will return to normal operation without storing the values of the eventually modified parameters.

USER / SUPER USER / FACTORY parameters access

DANGER

The modification of USER, SUPER USER or FACTORY parameters must be done by technical service personnel only.

Press **PRG** **mode** + **SEL** for more than 5 seconds.

The indication of “U” will appear on the display.

Use **▲** and **▼** buttons to set the value of password:

- 22 to access **USER** parameters;

Press **SEL** to confirm the password.

The display will show the code of the first available parameter.

The pressure of **▲** and **▼** allows to scroll sequentially all parameters.

The further pressure of **SEL** allows to display the selected parameter value, and the eventually modifying by means of **▲** and **▼** buttons.

The pressure of **SEL** button stores the new value of the modified parameters and permits to exit from the procedure, while **PRG** **mode** button allows to return to the parameter selecting menu.

On setting the parameters, the display will automatically flash after a few seconds if no buttons are pressed.

If no button has been pressed after 60 seconds from the procedure activation, the unit will return to normal operation without storing the values of the eventually modified parameters.

CHAPTER 9

PARAMETER TABLES

The presence of certain parameters in the various groups (probe, controller, compressor, etc.) depends on the type of the controller and on the value of some parameters identified by the following abbreviations indicated in the column “Pres. DFNPVX” of parameter tables:

D= only when the defrosting function has been enabled; $d0 \ 1=1$

F= only if the control of fans is present; $F0 \ 1<0$

N= only if the condensation probe is present; $r'04-r'08=2$

P= only if the condensation probe is present; $r'04-r'08=3$

V= if the driver is present; $H08=1-3$

X= expansion; $H08=2-3$

NOTE

Only in the 1.6 version of the software you can find the parameters P4, F 14. The version is displayed when the unit starts working.



9.1 Parameters related to the unit

		Description	Type	Pres. DFNPV X	Min.	Max.	M.U.	Step	Value after Reset	Default
H06	Summer / Winter digital input with P08 and P09 selected as 8/9	NOT USED, DO NOT MODIFY	U	-----	0	1	flag	1	0	0
H07	ON/OFF digital input	This parameter enables or disables the ON/OFF selection from digital input (see paragraph 8.7 "Remote control"). If the selection is enabled (H07=1) the "open" state forces the machine to stop, whereas with the "closed" state the machine can be started or stopped also from the keyboard.	U	-----	0	1	flag	1	0	0
H09	Lock of the keyboard	This parameter allows to disable the procedure through which can modify DIRECT and USER parameters through keyboard or through remote control (not present). However you will be able to display the parameter values. The following functions will also be disabled: Summer operation enabling / disabling, Winter operation enabling / disabling and resetting of contactors. H09=0: remote control enabled and keyboard disabled H09=1: remote control enabled and keyboard enabled H09=2: remote control disabled and keyboard disabled H09=3: remote control disabled and keyboard enabled	U	-----	0	3	flag	1	1	1
H 10	Serial address	It indicates the address of the instrument used to carry out serial connection, by means of optional card, to a supervisory and/or telemaintenance computer.	U	-----	000	200	flag	001	000	01

Table 14 PARAMETERS RELATED TO THE UNIT

9.2 Parameters related to the type of probes

		Description	Type	Pres. DFNPV X	Min.	Max.	M.U.	Step	Value after Reset	Default
r21	Digital filter	It allows to calculate the coefficient relative to the digital filter of the measured value. High values of this parameter allow to eliminate any noise at analogue input lines (but they decrease the sensitiveness of the probe). The value recommended is 4	U	-----	01	15	-	01	04	04
r22	Input limitation	This parameter allows to set the max. variation in the value detected by the probes during any cycle of the unit. The measure variation range is 0,1÷1,5 units (bar, °C or F according to the probe and the measurement scale) about every second. Giving this parameter low values allows to limit impulsive noise effects. Recommended value: 8.	U	-----	1	15	-	01	08	08
r23	Unit of measurement	It allows to set the operating mode either in degrees Centigrade or Fahrenheit. When the parameter changes, the electronic control automatically converts the values read by temperature probes NTC BTOWT, BEWOT, B3, B4 into the new unit of measurement; while all the other parameters being selected (set point, differential etc...) do not change. r23=0: °C r23=1: °F	U	-----	0	1	flag	1	0	0

Table 15 PARAMETERS RELATED TO THE TYPE OF PROBES

9.3 Probe reading parameters

		Description	Type	Pres. DFNPV X	Min.	Max.	M.U.	Step	Value after Reset	Default
b00	Configuration of probe to be shown on the display	Sets the probe reading to be displayed: <ul style="list-style-type: none"> • 0 = B1 BTOWT • 1 = B2 BTOWT • 2 = B3 probe • 3 = B4 probe • 4 = B5 probe • 5 = B6 probe • 6 = B7 probe • 7 = B8 probe • 8 = setpoint without compensation • 9 = dynamic setpoint with possible compensation 	U	-	0	9	Flag	1	0	0
b01	Value read by BTOWT probe	Indicates the value read by BTOWT probe	D	-	-	-	°C	-	-	-
b02	Value read by BEWOT probe	Indicates the value read by BEWOT probe	D	-	-	-	°C	-	-	-
b03	Value read by B3 probe	Indicates the value read by B3 probe Usable probe	D	-	-	-	°C	-	-	-
b04	Value read by B4 probe	Indicates the value read by B4 probe Enable probe with speed regulator, see r04	D	-	-	-	°C	-	-	-

Table 16 PROBE READING PARAMETERS

9.4 Parameters related to the compressor

		Description	Type	Pres. DFNPV X	Min.	Max.	M.U.	Step	Value after Reset	Default
c01	Minimum starting time	It sets the time-interval when the compressor must remain activated after it has been turned On, even if there is no more request for it.	U	-----	000	999	sec	001	060	060

Table 17 PARAMETERS RELATED TO THE COMPRESSOR



		Description	Type	Pres. DFNPV X	Min.	Max.	M.U.	Step	Value after Reset	Default
c02	Minimum stopping time	It sets the time-interval when the compressor must remain OFF after it has been turned OFF, even if there is a request for its turning ON. During this phase the LED relative to the compressor flashes.	U	-----	000	999	sec	001	060	120
c03	Delay time between two successive startings	It sets the minimum off time-interval between two successive startings of the compressor (it indicates the maximum number of startings per hour). During this phase the LED relative to the compressor flashes.	U	-----	000	999	sec	001	360	360
c04	Delay at start-up between two compressors	ONLY TWO COMPRESSOR UNITS In two compressor units it sets the delay time between the start-up of a compressor respect the other, even if there is the simultaneous request for both compressors. This allows to reduce the current absorption.	U	-----	000	999	sec	001	010	010
c05	Delay in switching OFF between two compressors	ONLY TWO COMPRESSOR UNITS In two compressors units it sets the delay time between the switching OFF of a compressor respect the other, even if there is the simultaneous request to turn OFF both compressors. This allows to save compressor.	U	-----	000	999	sec	001	000	000
c06	Delay at start-up	This parameter allows to set a time-delay at the compressor start-up (when you turn ON the unit by main switch) so as to balance current absorption and to protect the compressor from repeated start-up when there is some interruption in the power supply.	U	-----	000	999	sec	001	000	030
c07	Delay in switching ON compressor after switching ON the pump	With the pump actuated upon request of the controller, if the compressor activation is required, the controller will first actuate the pump and then the compressor. If the pump is always on, it will start only when you start the unit.	U	-----	000	150	sec	001	020	020
c08	Delay in switching OFF the pump when switching OFF compressor	With the pump actuated upon request of the controller, if the compressor deactivation is required, the controller will first deactivate the compressor and then the pump. If the pump is always on, it will be deactivated only in stand-by modality.	U	-----	000	150	min	001	001	001
c09	Max. time for compressor tandem operation	In the event of 2 tandem compressors per circuit, this parameter avoids that one compressor of the same circuit operates exceeding the pre-set time, while other remains off.	U	-----	000	060	min	001	000	000
c10	Hour-counter of compressor 1	It indicates the number of operating hours of the first compressor. The simultaneously pressure of and during the hour-counter value displaying resets the hour-counter and, consequently, the controller will not prompt the maintenance message.	D	-----	000	800	hours x 100	-	000	000
c11	Hour-counter of the second compressor 2	ONLY TWO COMPRESSOR UNITS It indicates the number of operating hours of the second compressor. The simultaneously pressure of and during the hour-counter value displaying resets the hour-counter and, consequently, the controller will not prompt the maintenance message.	D	-----	000	800	hours x 100	-	000	000
c14	Hour-counter threshold	It sets a threshold (operating hours of the compressor) after which the controller will prompt a request for maintenance. If the value is 0, this function will be ignored.	U	-----	000	100	hours x 100	001	000	020
c15	Hour-counter of evaporator pump	It displays the number of operating hours of the evaporator water circulation pump. The simultaneously pressure of and during the hour-counter value displaying resets the hour-counter.	D	-----	000	800	hours x 100	-	000	000
c16	Hour-counter of condenser pump	It displays the number of operating hours of the condenser water circulation pump. The simultaneously pressure of and during the hour-counter value displaying resets the hour-counter.	D	-----	000	800	hours x 100	-	000	000

Table 17 PARAMETERS RELATED TO THE COMPRESSOR

		Description	Type	Pres. DFNPV X	Min.	Max.	M.U.	Step	Value after Reset	Default
c 17	Min. time for pump stopping or before the next pump starting	It fixed the time between two successive startings of the pump.	U	-----	000	150	min	001	030	030
c 18	Min. time for pump starting	It is the minimum time the pump remains on.	U	-----	00	15	min	01	03	03

Table 17 PARAMETERS RELATED TO THE COMPRESSOR

9.5 Regulation parameters

		Description	Type	Pres. DFNPV X	Min.	Max.	M.U.	Step	Value after Reset	Default
r01	Set Point	It allows to set the Summer set-point value.	D	-----	r13	r14	see r23	00.1	12.0	07.0
r02	Differential	It allows to set the Summer differential value.	D	-----	00.3	19.9	see r23	00.1	03.0	04.0
r03	Winter set point	It allows to set the Winter set-point value.	D	-----	r15	r16	see r23	00.1	40.0	45.0
r04	Winter differential	It allows to set the Winter differential value.	D	-----	00.3	19.9	see r23	00.1	03.0	04.0
r13	Min. summer set	It fixes the min. limit for the summer set point setting.	U	-----	-40.0	r14	°C	00.1	-40.0	5
r14	Max. summer set	It fixes the max. limit for the summer set point setting.	U	-----	r13	80.0	°C	00.1	80.0	30.0
r15	Min. winter set	It fixes the min. limit for the winter set point setting.	U	-----	-40.0	r16	°C	00.1	-40.0	5
r16	Max. winter set	It fixes the max. limit for the winter set point setting.	U	-----	r15	80.0	°C	00.1	80.0	50.0
r17	Compensation constant	It fixes the coefficient which regulates the compensation algorithm.	U	-----	-05.0	05.0	°C	00.1	00.0	00.0
r18	Max. distance of set point	It indicates the max. distance of set point, over this limit the compensation is stopped (max. and min. limits according to the pre-fixed set point).	U	-----	00.3	20.0	°C	00.1	00.3	00.3
r19	Temperature at compensation start during summer modality (external probe)	It fixes the temperature (measured by the external probe) at which the compensation effect starts (cooling).	U	-----	-40.0	176.0	°C	00.1	30.0	30.0
r20	Temperature at compensation start during winter modality (external probe)	It fixes the temperature (measured by the external probe) at which the compensation effect starts (warming).	U	-----	-40.0	176.0	°C	00.1	00.0	00.0
r21	Second summer set point by external contact	It is the alternative to r01 if the digital inlet is closed and if the parameter is appropriately regulated.	D	-----	r13	r14	°C	00.1	12.0	12.0
r22	Second winter set point by external contact	It is the alternative to r03 if the digital inlet is closed and if the parameter is appropriately regulated.	D	-----	r15	r16	°C	00.1	40.0	40.0
r31	Heating compensation constant	Sets the coefficient that controls the heating compensation algorithm.	U	-----	-5.0	5.0	-	0.1	0.0	0.0

Table 18 REGULATION PARAMETERS



9.6 Fan operation parameters

		Description	Type	Pres. DFNPV X	Min.	Max.	M.U.	Step	Value after Reset	Default
<i>F02</i>	Fan outlet	Determines the operating logic of the fans: <i>F02</i> =0: always ON at the max. speed, independently of the compressors. The fans are stopped only if the unit is stopped or put in stand-by. <i>F02</i> =1: ON at the max. speed when at least one compressor of the circuit is on (parallel operation for each circuit). <i>F02</i> =2: ON when the appropriate compressor is ON, with ON/OFF regulation according to the temperatures/pressures of min. and max. speed (parameters <i>F05</i> , <i>F06</i> , <i>F07</i> and <i>F08</i>). When the compressor are turned OFF, the relative fans are deactivated independently of the condensation temperature/pressure. <i>F02</i> =3: on when the corresponding compressor with speed regulator is on. When the compressors switch off, so do the corresponding fans, apart from the condensing temperature/pressure. <i>F02</i> =3 and condensing probe NTC: when the compressor starts working the fans work at the maximum speed for the time set by apart from the measured temperature. If the condensing probe is broken, the fans stop.	U	-F----	0	1	flag	1	0	2 Speed regulator <i>F02</i> =3
<i>F04</i>	Maximum tension threshold for Triac	See description <i>F03</i> . <i>F04</i> : is the max. threshold.	U	-F----	<i>F03</i>	100	flag	1	75	75
<i>F05</i>	Temperature/Pressure set for min. speed in Summer modality	It indicates the temperature or the pressure below which the fans are actuated at minimum speed. In ON/OFF regulation models, this parameter indicates the temperature or the pressure below which the fans are stopped.	U	-FN---	-40.0	80.0	<i>r23</i>	00.1	35.0 °C 95.0 °F	35.0 °C 95.0 °F
			U	-F---P	<i>r11</i>	<i>r12</i>	bar	00.1	13.0bar	12.0 bar
<i>F06</i>	Temperature/Pressure differential for max. speed in Summer modality	If a speed regulator is used, it is the differential with respect to <i>F05</i> of the temperature or pressure over which the fans must be started at the max. speed; in this case the ON/OFF regulation indicates the temperature or pressure over which the fans are started.	U	-FN---	00.0	50.0	<i>r23</i>	00.1	10.0 °C 18.0 °F	13.0 °C 23.4 °F
			U	-F---P	00.0	30.0	bar	00.1	3.0bar	5.0 bar
<i>F07</i>	Temperature/Pressure differential for stopping in Summer modality	If a speed regulator is used, it is the differential with respect to <i>F05</i> of the temperature or pressure under which the fans are stopped. If for condensate control are used NTC temperature probes or pressure probes, the starting is an hysteresis of 1°C or 0,5°C.	U	-FN---	00.0	50.0	°C	00.1	15.0 °C 27.0 °F	10.0 °C 18.0 °F
			U	-F---P	00.0	<i>F05</i>	bar	00.1	5.0bar	2.0 bar
<i>F08</i>	Temperature/Pressure set for min. speed in Winter modality	It indicates the temperature or the pressure over which the fans must be On at the min. speed. In ON/OFF regulation models, this parameter indicates the temperature or the pressure over which the fans are stopped.	U	-FN---	-40.0	80.0	°C	00.1	35 °C 95 °F	35.0 °C 95.0 °F
			U	-F---P	00.0	30.0	bar	00.1	13.0bar	13.0 bar
<i>F09</i>	Temperature/Pressure differential for max. speed in Winter modality	If a speed regulator is used, it is the differential with respect to <i>F08</i> of the temperature or pressure under which the fans are started at the max. speed. In ON/OFF regulation, it indicates the temperature or pressure for starting.	U	-FN---	00.0	50.0	°C	00.1	05.0 °C 09.0 °F	05.0 °C 09.0 °F
			U	-F---P	00.0	<i>F08</i>	bar	00.1	04.0bar	04.0 bar
<i>F10</i>	Temperature/Pressure differential for stopping in Winter modality	If a speed regulator is used, it is the differential with respect to <i>F08</i> of the temperature or pressure over which the fans are stopped. If for condensate control are used NTC temperature probes or pressure probes, the starting is an hysteresis of 1°C or 0,5°C.	U	-FN---	00.0	<i>F08</i>	°C	00.1	05.0 °C 09.0 °F	05.0 °C 09.0 °F
			U	-F---P	00.0	30.0	bar	00.1	03.0bar	03.0 bar

Table 19 FAN OPERATION PARAMETERS

		Description	Type	Pres. DFNPV X	Min.	Max.	M.U.	Step	Value after Reset	Default
F11	Fan starting time	It fixes the operating period to the max. speed of the fans during starting, in order to overcome the mechanical inertia of the motor. F11=0: the function is not carried out (disabled), that is that the fans are started at the min. speed and controlled according to the condensation temperature/pressure.	U	-F----	000	120	sec	001	000	004
F14	Max. ventilation time with high temperature of the condenser	It sets the length of time of the forced ventilation if the machine starts working with high condenser temperature. F14 = 0: enabled function. F14 > 0: forced ventilation time (seconds) The function is operational only in chiller mode, if the condensing probe is on, for air condensated units.	U	-FN---	000	999	sec	001	000	000

Table 19 FAN OPERATION PARAMETERS

9.7 Antifreeze protection and resistance control parameters

		Description	Type	Pres. DFNPV X	Min.	Max.	M.U.	Step	Value after Reset	Default
A01	Antifreeze alarm set point / low temperature	This represents the temperature of the water at the evaporator outlet below which an antifreeze alarm is activated; in this condition the compressor is stopped, while the pump remains on. The alarm is reset manually (or automatically) only when the water temperature returns within the operating limits (that is, above A01+A02).	U	-----	A7	A4	°C	00.1	03.0	01.0
A02	Antifreeze alarm differential/low temperature	This represents the differential for the activation of the antifreeze alarm; the alarm condition cannot be reset until the temperature exceeds the set point + differential (A01+A02).	U	-----	00.3	19.9	°C	00.1	05.0	04.0
A03	Antifreeze alarm bypass time/low temperature from unit start in Winter mode	This represents the delay in the activation of the antifreeze alarm when starting the system. In the case of air/air units, this parameter represents the delay time for the low room temperature (return-intake air) signal, only in winter mode (when it is necessary to warm). This means that the room being heated is too cold (threshold set by the user).	U	-----	000	150	sec	001	000	000
A04	Antifreeze heater set point in cooling	Determines the threshold below which the antifreeze heaters are switched on. The starting function of antifreeze heaters is enabled when the unit is in stand by.	U	-----	A01	r16	°C	00.1	05.0	05.0
A05	Auxiliary heater differential during unit cooling operation	Differential for the activation and deactivation of the antifreeze heaters.	U	-----	00.3	50.0	°C	00.1	01.0	01.0
A08	Auxiliary heater set point in heating mode	Represents the threshold below which the auxiliary heaters are ON. This function is enabled only in heating units. When HD1=5, 10 in heating mode, the probe becomes B3.	U	-----	A01	r15	r23	00.1	25.0	25.0
A09	Auxiliary heater differential in heating mode	Represents the differential for the activation/deactivation of the auxiliary heaters (see AB). This function is enabled only in heating units.	U	-----	00.3	50.0	r23	00.1	03.0	03.0

Table 20 ANTIFREEZE PROTECTION AND RESISTANCE CONTROL PARAMETERS

		Description	Type	Pres. DFNPV X	Min.	Max.	M.U.	Step	Value after Reset	Default
<i>R 10</i>	Automatic start for antifreeze	This parameter is valid when the unit is in standby. The operating mode switchover delay times are ignored. <i>R 10</i> =0: function not enabled <i>R 10</i> =1: auxiliary heaters and pump are ON at the same time, based to the respective set points: <i>RD4</i> or <i>RD8</i> <i>R 10</i> =2: auxiliary heaters and pump ON independently based on the respective set points: <i>RD4</i> or <i>RD8</i> <i>R 10</i> =3: auxiliary heaters ON based on the respective set points: <i>RD4</i> or <i>RD8</i>	U	-----	0	3	flag	1	0	1

Table 20 ANTIFREEZE PROTECTION AND RESISTANCE CONTROL PARAMETERS

9.7.1 Antifreeze function tripping logic

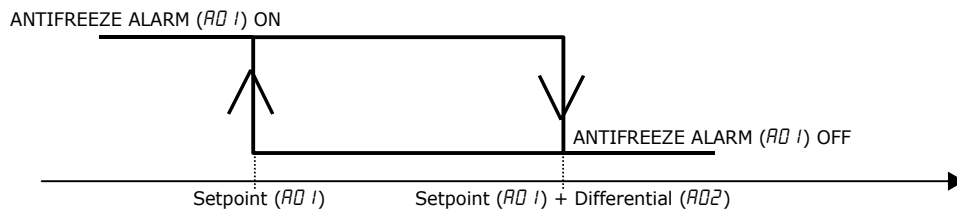

9.8 Alarm setting parameters

		Description	Type	Pres. DFNPV X	Min.	Max.	M.U.	Step	Value after Reset	Default
<i>P01</i>	Flow switch alarm delay when starting pump	Establishes a delay in the recognition of the flow switch alarm when starting the pump.	U	-----	000	150	sec	001	020	010
<i>P02</i>	Flow switch alarm delay in steady operation	Establishes a delay in the recognition of the flow switch alarm in steady operation, so as to filter any variations in flow-rate or air bubbles present in the water circuit.	U	-----	000	120	sec	001	005	005
<i>P03</i>	Low pressure alarm delay at compressor start	Establishes a delay in the recognition of the low pressure alarm when the compressor starts, so as to allow stable operating conditions to be reached.	U	-----	000	200	sec	001	040	120
<i>P04</i>	Enabling of the capacity control with high pressure.	Enables or disables the capacity control of the high pressure circuit.	U	---P--	0	1	flag	1	0	0
<i>P 16</i>	High temperature alarm set point	Represents the high temperature alarm threshold (detected by probe BTOWT); the differential is set at 2°C and the alarm is reset automatically (the warning relay is activated, signal only, and the message "HE" is shown). When starting the system, this alarm is regulated by the time fixed by parameter "P 17".	U	-----	-40.0	80.0	°C	00.1	80.0	60.0
<i>P 17</i>	High temperature alarm delay on power-up	High temperature alarm delay when the control is switched on (power ON), from the remote ON/OFF contact or from the keypad.	U	-----	000	250	min	001	030	180
<i>P 19</i>	Low system start-up temperature alarm set point	Represents a low temperature alarm threshold (measured by probe BTOWT); it is reset automatically (the alarm relay is not activated and the display shows the message "AL").	U	-----	-40.0	80.0	°C	00.1	10.0	60.0

Table 21 ALARM SETTING PARAMETERS

		Description	Type	Pres. DFNPV X	Min.	Max.	M.U.	Step	Value after Reset	Default
P20	System start-up protection	System start-up protection for high/low temperature P20=1: enables the system protection function when starting, both at power ON and when switching ON from Standby. P20=0: the function is not enabled.	U	-----	0	1	flag	1	0	0

Table 21 ALARM SETTING PARAMETERS

9.9 Defrost parameters

		Description	Type	Pres. DFNPV X	Min.	Max.	M.U.	Step	Value after Reset	Default
d01	Defrosting cycle/ Condenser antifreeze	For heat pumps with air-cooled condensers, this establishes whether defrost control must be performed on the outdoor exchanger (evaporator in winter mode). On the other hand, for water/water heat pumps with reversal on the gas circuit, it enables antifreeze control on the cooling water for the outdoor exchanger (evaporator in Winter mode) see d03. d01=0: not d01=1: yes.	U	-----	0	1	flag	1	1	0

Table 22 DEFROST PARAMETERS

CHAPTER 10

ALARM AND SIGNALLING

Any time an alarm condition is detected, the controller will prompt the following actions:

- the buzzer sounds (if previously enabled, see *P4* parameter and if the machine is not in stand-by)
- the alarm relay is activated
- the temperature value flashes on display
- the alarm code appears on the display alternatively with the temperature value

After the alarms have been cleared either with automatic reset or by pressing and buttons simultaneously for 5 seconds (for alarms with manual reset), the following actions will occur:

- the buzzer silences
- the alarm relay de-energises
- the temperature value stops flashing
- the alarm code disappears from the display

If the alarm condition persists, the actions described above will be performed again.

The control board allows to detect contemporaneously also more alarm signalings.

10.1 Buzzer silencing (if it is present)

The pressure of button silences the buzzer, if the buzzer is activated.

10.2 Alarms reset

The contemporaneous pressure of and buttons for more than 5 seconds resets any alarm condition (manual reset), disables the alarm message shown in the display and it resets the alarm relay.

10.3 Hour-counter zero setting

When the hour-counter of compressors operation or the hour-counter of pump operation is displayed (parameters *c 10*, *c 11*, *c 12*, *c 13*, *c 15*) the contemporaneous pressure of and allows its immediate zero setting.

In this way the eventual compressor and pump maintenance signalling will be disactivated.

10.4 Alarm and signalling table

Display	Type	Description	Reset	Compr.	Pump	Fan	Resist.	Alarm
<i>HP 1</i>	High pressure/ compressor outlet temperature	The alarm condition is detected independently of the status of the pump and compressors. The compressor is immediately forced into the OFF mode (previously set protection time-intervals are ignored) and at the same time the buzzer, the alarm relay and the lighting of the display are activated. Fans are activated at max. speed for 60s to face the alarm situation. After this period they are stopped.	manual	OFF	-	ON (60s)	-	ON
<i>LP 1</i>	Low pressure	The alarm condition is detected with the compressor ON or OFF, independently of the status of the pump. The compressor is forced into the OFF mode immediately or is not turned ON and at the same time the buzzer, the alarm relay and the lighting of the display are activated.	manual	OFF	-	OFF	-	ON
<i>EP</i>	Automatic/ thermal protection of compressor	The alarm condition is detected independently of the pump and compressor status. Stops the compressor (ignoring the protection timing), the pump, the fan, the buzzer, the alarm relay and the display flashing are activated. Reset is possible both manually and automatically.	manual	OFF	OFF	OFF	-	ON
<i>EC 1</i>	Thermal protection of compressor	The alarm condition is detected independently of the pump and compressor status. Stops the compressor (ignoring the protection timing), the pump, the fan, the buzzer, the alarm relay and the display flashing are activated. Reset is possible both manually and automatically.	manual	OFF	-	OFF	-	ON
<i>LR</i>	Warning	This represents a generic warning that appears on the display, from digital input, without modifying the operation of the unit. With the 1st circuit module only, the alarm relay is activated, while with the expansion card the warning relay can be used. Reset is possible both manually and automatically.	manual	-	-	-	-	ON

Table 23 ALARM AND SIGNALLING TABLE



Display	Type	Description	Reset	Compr.	Pump	Fan	Resist.	Alarm
<i>FL</i>	Tank level/ pump thermal protection/ pump/fan automatic switch Flow switch (option)	This alarm is detected only if the pump is ON (excluding the delays when starting P1 and in steady operation P2), irrespective of the status of the compressor. All of the outputs are disabled: pump, compressor (without observing the OFF times), condenser fan, and the buzzer sounds, the alarm relay is activated and the display flashes. The presence of the water pump must be enabled. It can be reset either manually or automatically.	automatic	OFF	OFF	OFF	-	ON
<i>E1, E2, E3</i>	Probes (BTWOT, BEWOT, B3)	They are detected also with the unit in stand-by. The presence of a probe alarm forces into the OFF mode the compressor, the condensation fans and the pump. The buzzer, the alarm relay and the display flashing are activated.	automatic	OFF	OFF	OFF	-	ON
<i>Hc1</i>	Compressor operating hour limit exceeded warning	When the number of operating hours for the compressor exceeds the maintenance threshold (as default equal to zero, and consequently the function is disabled), the maintenance request signal is activated. The buzzer and the alarm relay are not activated, however the warning relay is activated (with the expansion card fitted).	automatic	-	-	-	-	-
<i>EP_r</i>	Eeprom error	A problem has occurred when saving the parameters to the unit's non-volatile memory (eeprom); in the event of an Epr error, the μC^2 continues to perform the control functions with the data present in the volatile memory (RAM), where there is a physical copy of all of the data. After the first power failure the configuration will be lost. The buzzer and the alarm relay are not activated. If the occurs when starting the unit, "EPb", the controller will not operate.	automatic	-	-	-	-	ON
<i>EP_b</i>			automatic	OFF	OFF	OFF	OFF	OFF
<i>ESP</i>	Communication error with expansion card	If the controller loses communication with the expansion card, the entire system will be stopped to avoid adversely affecting the unit. The alarm relay is activated and the display will show the message, with the red LED on steady.	automatic	OFF	OFF	OFF	OFF	ON
<i>EL1</i>	Warning, zero crossing error circuit 1	If the controller detects errors in the power supply, control may be lost over the fan speed. In this case, the display will show a warning, and the fans will be controlled at maximum speed, if at least one compressor is on. The alarm is reset automatically, so as to not affect the operation of the unit. If the expansion card is used, the warning relay is activated.	automatic	-	-	100%	-	ON
<i>dF1</i>	Warning, end defrost circuit 1 due to maximum time	If the defrost ends after the maximum time when end defrost by temperature or from external contact has been selected. The message is cancelled using the delete alarm procedure or when the next correct defrost cycle is completed. The buzzer and the alarm relay are not activated. If the expansion card is used, the warning relay is activated (if used).	automatic	-	-	-	-	-
<i>A1</i>	Antifreeze alarm	The alarm is only detected in water chillers by the evaporator water outlet probe (BEWOT/B6). The compressors in circuit 1 and the condenser fans in circuit 1 are immediately stopped, the buzzer and alarm relay are activated, and the display starts flashing. If the μC^2 is in stand-by, the alarm condition is not detected, and only the heaters are managed. After the time <i>AD3</i> , if the alarm persists the unit will stop again.	manual	OFF	-	OFF	-	ON
<i>Ht</i>	High temperature warning	This alarm is activated when the threshold is exceeded (read by BTWOT), set for the parameter <i>P15</i> . It is delayed at power ON by the parameter <i>P17</i> and causes the activation of the alarm relay and the buzzer, without deactivating the outputs. It is reset automatically when conditions that caused the alarm are no longer present.	automatic	-	-	-	-	ON

Table 23 ALARM AND SIGNALLING TABLE

Display	Type	Description	Reset	Compr.	Pump	Fan	Resist.	Alarm
<i>Lt</i>	Low temperature warning	For direct expansion units the alarm is used to measure a low room temperature using probe BTWOT or BEWOT. The alarm may be reset manually or automatically, and depends on the parameter <i>POS</i> . If the expansion is present, the corresponding relay is activated; in the event of μC^2 module only, the alarm relay will be used.	manual	-	-	-	-	ON
<i>AHt</i>	High temperature warning when starting the system	The advice does not activate the relay, and displays the message " <i>AHt</i> ".	automatic	OFF	-	OFF	OFF	ON
<i>ALt</i>	Low temperature warning when starting the system	The advice does not activate the relay, and displays the message " <i>ALt</i> ".	automatic	OFF	-	OFF	OFF	ON
<i>ELS/EHS</i>	Warning, low/high power supply alarm	If the power supply voltage is too low or too high, the corresponding message is displayed. In these cases, the correct operation of the μC^2 is no longer guaranteed. In the low voltage conditions only the requests to deactivate the loads are effected. Any start-up requests remain pending. The high voltage condition involves the deactivation of all the energised relays.	automatic	OFF	OFF	OFF	OFF	OFF
<i>Ed 1</i>	tLan communication error with Driver 1	The alarm is generated after a fixed time (5 seconds) from when the μC^2 loses contact with Driver 1. In this case, circuit 1 is disabled for safety reasons.	automatic	OFF	-	OFF	-	ON
<i>SH 1</i>	Low superheat alarm circuit 1	The low superheat alarm for circuit 1, after a fixed time (5 seconds), inhibits the circuit 1 for safety reasons.	-	OFF	-	OFF	-	ON
<i>PO 1</i>	MOP warning (maximum operating pressure) circuit 1	The warning appears on the display and, if the expansion card is fitted, the corresponding relay is activated.	automatic	-	-	-	-	-
<i>LO 1</i>	LOP warning (lowest operating pressure) circuit 1	The warning appears on the display and, if the expansion card is fitted, the corresponding relay is activated.	automatic	-	-	-	-	-
<i>HA 1</i>	High evaporator temperature warning circuit 1	The warning appears on the display and, if the expansion card is fitted, the corresponding relay is activated.	automatic	-	-	-	-	-
<i>EP 1</i>	Eeprom error driver	The circuit 1 is disabled for safety reasons, as the status of Driver 1 is not known.	automatic	OFF	-	OFF	-	ON
<i>ES 1</i>	Probe error driver 1	The circuit 1 is disabled for safety reasons, as the status of Driver 1 is not known.	automatic	OFF	-	OFF	-	ON
<i>EU 1</i>	EVD 1 error, valve open when starting	If when starting the system the Driver detects that the valve is still open, an alarm is sent to the μC^2 that stops the compressors and the fans in the corresponding circuit.	automatic	OFF	-	OFF	-	ON
<i>Eb 1</i>	EVD 100 battery alarm	The EVD 100 battery alarm stops the compressors from starting so as to prevent the risk of liquid returning to circuit 1.	automatic	OFF	-	OFF	-	ON
<i>L</i>	Low load warning	The warning does not activate the relay and displays the message " <i>L</i> "; reset is automatic.	automatic	-	-	-	-	-

Table 23 ALARM AND SIGNALLING TABLE

Display	Type	Description	Reset	Compr.	Pump	Fan	Resist.	Alarm
<i>FLb</i>	Backup pump warning	The warning activates the warning relay and displays the message " <i>FLb</i> "; reset is manual. This indicates the operation of the backup pump (if present) due to a probable fault on the main pump, suggesting that maintenance is required. If the flow alarm features automatic reset, the controller will make 10 attempts to re-start the pumps, after which the <i>FL</i> alarm will replace <i>FLb</i> . If the flow alarm features manual reset, when first activated the controller will display the alarm <i>FLb</i> , switching over the pumps; when activated again the <i>FL</i> alarm will replace <i>FLb</i> .	automatic	-	-	-	-	ON
<i>Ed 1</i>	tLan communication error with Driver 1	The alarm is generated after a fixed time (5 seconds) from when the μC^2 loses contact with Driver 1. In this case, circuit 1 is disabled for safety reasons.	automatic	OFF	-	OFF	-	ON

Table 23 ALARM AND SIGNALLING TABLE

NOTE

Putting in stand by the electronic board with at least the presence of an alarm, all signalings remain activated except the buzzer which stops. Furthermore, with the unit already in stand by, no alarm is detected except system alarms (that is only system alarms are managed, not the digital input alarms).

COMPONENTS SETTING

11.1 High and low pressure switches

The units are fitted with the following pressure switches:

1. low pressure switch (LP)

This monitors refrigerant compressor intake pressure and will trip to avoid that values dangerous for compressor normal operation are reached.

It is of an “automatic reset” type.

The alarm *LP I*, produced by this pressure switch tripping (see Chapter 10 “Alarm and signalling”), can have a delay time after the compressor starting, by *PO3* parameter to avoid simple intake pressure fluctuations or false alarms interfere with the unit normal operation.

After *PO3* time, the pressure switch tripping will be detected by the electronic board which will display the alarm signal *LP I* and will stop the compressor and the fan while the pump (if it is installed) will continue to operate.

After the alarm tripping, if the compressor intake pressure increases and exceeds the pressure switch tripping value it will restart.

It will be possible to start up the unit again following the alarm reset procedure described in Chapter 8 “Electronic control”. If the cause of the pressure switch tripping has not removed this cycle will repeat continuously.

2. high pressure switch (HP)

This monitors the refrigerant compressor discharge pressure and prevents it increases to levels dangerous to the operation of the compressor and people safety.

It is of an “automatic reset” type.

Its tripping is detected by the electronic board which will open the compressor power circuit and will display the alarm signal *HP I* (see Chapter 10 “Alarm and signalling”).

When the compressor outlet pressure drops below the reset point it is reset.

It will be possible to start up the unit again following the alarm reset procedure described in Chapter 8 “Electronic control”. If the cause of the pressure switch tripping has not removed this cycle will repeat continuously.

The pressure switches LP and HP are screwed to the refrigerant circuit piping with SCHRAEDER valves (with needle) which prevent leakage during replacement.

The TRIP and RESET values of the pressure switches depend upon the refrigerant gas used and are listed in the table below:

Pressure switch	Refrigerant	TRIP			RESET		
		bar	°C	°F	bar	°C	°F
HP	R407c	27.2	63.4	146.1	20.5	51.5	124.7
	R22	27.2	66.9	152.4	20.5	54.4	129.9
LP	R407C	1.7	-17.3	0.9	2.7	-8.8	16.2
	R22	1.7	-17.8	0	2.7	-8.9	16.0

Table 24 SETTING OF LP, HP PRESSURE SWITCHES

Fan pressure switch and fan speed regulator

3. fan pressure switch (PV)

In these units a pressure switch detects the refrigerant compressor outlet pressure and controls the fan operation powering them on or off.

The pressure switch PV is screwed to the refrigerant circuit piping with SCHRAEDER valves (with needle) which prevent leakage during replacement.

The TRIP and RESET values of the pressure switch depend upon the refrigerant gas used and are listed in the table below:

Pressure switch	Refrigerant	TRIP			RESET		
		bar	°C	°F	bar	°C	°F
Axial fans PV	R407C	18	46.4	115.5	14	37.0	98.6
	R22	18	49	120.2	14	39.2	102.6
Centrifugal fans TAEevo 031÷051 PV	R407C	18	46.4	115.5	14	37.0	98.6
	R22	18	49	120.2	14	39.2	102.6
Centrifugal fans TAEevo 081÷161 PV1	R407C	16.3	42.6	108.7	12.5	32.9	91.2
	R22	16.3	45.1	113.2	12.5	35	95

Table 25 SETTING OF PV PRESSURE SWITCH

Pressure switch	Refrigerant	TRIP			RESET		
		bar	°C	°F	bar	°C	°F
Centrifugal fans TAEevo 081÷161 PV2	R407C	18	46.4	115.5	14	37.0	98.6
	R22	18	49	120.2	14	39.2	102.6

Table 25 SETTING OF PV PRESSURE SWITCH

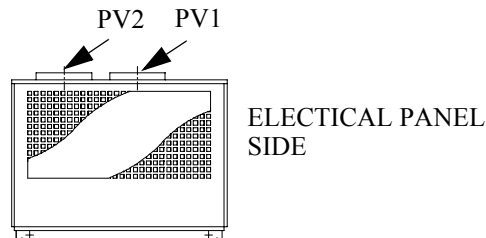

4. fan speed regulator

The unit is furnished with a speed regulator of fan rotation, which operates to maintain the condensing pressure within a pre-fixed value.

These units are furnished with a pressure transducer positioned on the refrigerant compressor outlet pipeline.

It commutates the measured pressure value into an electric signal, sent to the speed regulator.

For example, if the temperature of the air sent to the condenser decreases, the pressure transducer will measure a decreasing of the condensing pressure. This pressure decreasing is sent to the speed regulator which will reduce the fan speed and consequently, the condenser air flow will be reduced.

Analogously, when the air temperature to the condenser and the condensing pressure increase, the regulator will increase continuously the fan speed to increase the air flow through the condenser.

The following graphic shows the progress of the fan rotation speed according to the condensing pressure changings.

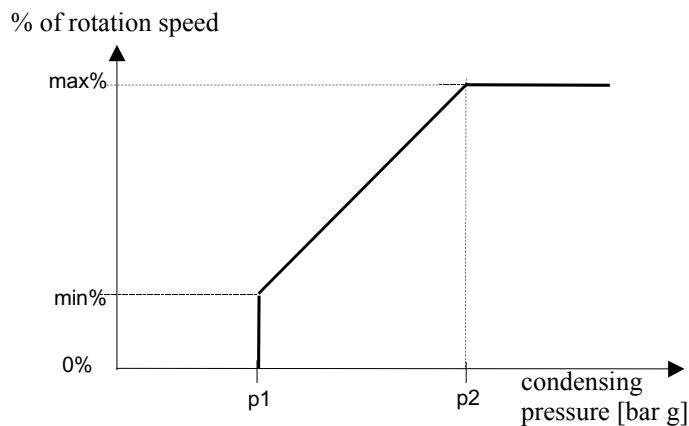

NOTE

Both P1 and P2 pressures and the min. /max fan rotation can be set by the electronic control.

11.2 Level sensor

All units are equipped with a level sensor.

This sensor is installed inside the tank and is used to detect eventual water losses. In case of water losses, the sensor sends an alarm signal to the control board which immediately blocks the unit.

OPERATION AND MAINTENANCE

12.1 Operation

The machine operates in completely automatic mode.

There is not necessary to turn it off when there is no thermal load as it turns off automatically when the preset water outlet temperature has been reached.

12.2 Maintenance

ATTENTION

Before proceeding with the installation or the maintenance of these units be sure that all personnel concerned have read and understood the Chapter 3 "Safety".

These machines will give many years of trouble-free service if they are properly maintained and serviced.

12.2.1 Unit access

To access the components of the refrigerant circuit use an appropriate key furnished with the unit and operate on the closing bolts of the front panel (A). In TAEevo 015÷020 the front panel (A) is fixed with screws (see figure).

The access to the evaporator and to the components of the hydraulic circuit can be carried out by unscrewing, by a screwdriver, the screws fixing the back panel (B) (see figure).

In units from TAEevo 081 to 161, the access to the components of the refrigerant circuit can be also carried out by removing the side panel of the condensing coil.

ATTENTION

To access to the components of the electrical panel, after positioning the main switch on "OFF" position, for TAEevo 031÷161 open the doors of the electrical panel (C) operating on the closing bolts with the appropriate key furnished with the unit; for TAEevo 015÷020, remove the screws fixing the door of the electrical panel (C).

TAEevo 015÷020

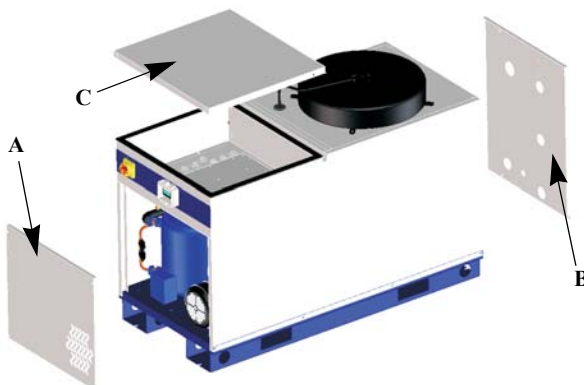

TAEevo 031÷161

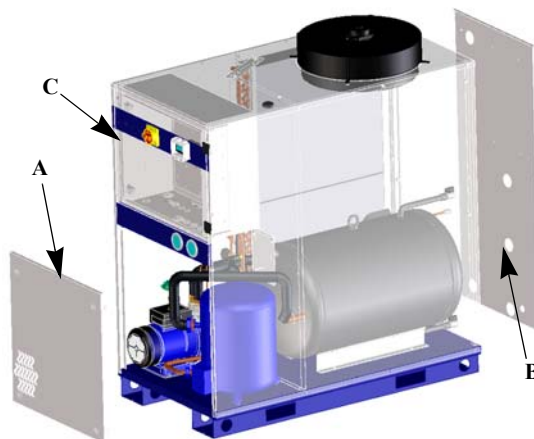

12.2.2 Water circuit emptying

In the event of maintenance operations which require the water circuit emptying, in models with hydraulic group there is a cock positioned in the low part of the tank which allows to discharge the water.

ATTENTION

The water circuit emptying operation becomes indispensable when the unit is without antifreeze resistance and must remain OFF for a long time in an ambient with temperatures which could reach the freezing values of water inside the evaporator (risk of evaporator breaking).



12.3 Maintenance schedule

OPERATION	1 day	1 month	6 months	annually
Check for any alarm signals.	x			
Check that the water outlet temperature is within the envisaged range.	x			
Check that the water inlet temperature is in accordance with the value used for selecting the unit.		x		
In units with hydraulic group check that the pressure in the tank (with pump stopped) is about 0.5 bar.		x		
In units with hydraulic group check that the difference between the pump outlet pressure and inlet pressure (measured by a pressure gauge with the pump stopped) is within the limits envisaged and, in particular, is not lower than the value corresponding to the maximum flow.		x		
Clean the water filter. We recommend to clean the filter after a week from the unit starting.		x		
Check that the liquid indicator (if present) is full or with a small stream of bubbles when the compressor is running.			x	
Check that the unit current absorption is within the values on the data plate.			x	
Carry out visual inspection of refrigerant circuit, looking out for any deterioration of the piping or any traces of oil which might indicate a refrigerant leak.			x	
Check the condition and security of piping connections.			x	
Check the condition and security of electrical connections.			x	
Using a spanner, check that the connections between the compressor inlet and outlet pipelines have not slackened.			x	
Check that the ambient air temperature is in accordance to the value used for selecting the machine (normally 30-35°C / 77-86°F). Check that the ambient is well ventilated.		x		
Check that the fan operation is automatically started up. Clean the condenser fins with a soft sponge or a jet of clean compressed air. Check that the grilles of the unit are free from dirt and any other obstructions.			x	
Clean condenser fins with a mild detergent.				x

Table 26 MAINTENANCE SCHEDULE

ATTENTION

- *This plan is based on an average working situation.*
- *In some installations it may be necessary to increase the frequency of maintenance.*





TROUBLE SHOOTING

PROBLEM	CAUSE	SYMPTOM	REMEDY
A Water outlet temperature BTOWT higher than the expected value.	A1 Thermal load too high.	A1.1 <ul style="list-style-type: none"> • Temperature BTOWT higher than expected value; • alarm <i>HE</i> trips. 	Restore the thermal load within the preset limits.
	A2 Ambient temperature too high.	A2.1 See A1.1.	In the event of indoor installation, if possible restore the ambient temperature within the preset limits, e.g. by increasing the local ventilation.
	A3 Condenser fins dirty.	A3.1 See A1.1.	Clean the condenser fins.
	A4 Front surface of the condenser obstructed.	A4.1 See A1.1.	Free the front surface of the condenser.
	A5 No refrigerant fluid in the plant.	A5.1 <ul style="list-style-type: none"> • See A1.1; • low evaporation pressure; • if the liquid indicator is present, check the presence of bubbles. 	Get a refrigerator technician to check for leaks and eliminate them. Fill the plant.
	A6 Compressor protection trips.	A6.1 <ul style="list-style-type: none"> • The head and the body of the compressor are very hot; • the compressor stops and tries to restart after a short period (even a few seconds). 	Get a refrigerator technician to check for leaks and eliminate them. Fill the plant.
B Low head values (water pressure) at pump outlet.	B1 Water flow too high. The pump doesn't work properly (water flow too high, low head value, high absorbed power).	B1.1 <ul style="list-style-type: none"> • Possible increase in the outlet temperature BTOWT (See A1.1); • with pump installed on the machine: pressure difference, read on the machine pressure gauge, too low with pump stopped and pump running; • possible tripping of the pump thermal protection device. 	Restore the flow within the preset limits, e.g. by partially closing the pump outlet cock. Reset the pump thermal protection device and check the electrical absorption.

Table 27 TROUBLE SHOOTING



PROBLEM	CAUSE	SYMPTOM	REMEDY
C High pressure switch (HP) or safety thermostat trips Alarm displayed <i>HP 1</i>	C1 Fan doesn't work.	C1.1 <ul style="list-style-type: none"> Refrigerant compressor stops; the code "<i>HP 1</i>" is displayed alternately with the value BTOWT; main alarm relay tripped. 	Repair or replace the fan. Check the eventual thermal protection switch of the fan. Follow the alarm reset procedure to start up the unit again (Chapter 8 "Electronic control").
	C2 Ambient air temperature too high.	C2.1 <ul style="list-style-type: none"> Ambient air temperature higher than maximum permitted value; See C1.1. 	In the event of indoor installation, if possible reduce ambient temperature within design limits, for example by increasing local ventilation. Follow the alarm reset procedure to start up the unit again (Chapter 8 "Electronic control").
	C3 Recirculation of warm air due to incorrect installation location.	C3.1 <ul style="list-style-type: none"> Condenser thermal exchanging temperature higher than the permitted value; See C1.1. 	Change the position of the unit or the position of any adjacent obstructions to avoid recirculation. Follow the alarm reset procedure to start up the unit again (Chapter 8 "Electronic control").
	C4 See A3.	C4.1 See C1.1	Clean the condenser fins. Follow the alarm reset procedure to start up the unit again (Chapter 8 "Electronic control").
	C5 See A4.	C5.1 See C1.1	Remove obstruction from condenser front surface. Follow the alarm reset procedure to start up the unit again (Chapter 8 "Electronic control").
	C6 Thermal load too high.	C6.1 <ul style="list-style-type: none"> Water outlet temperature too high; refrigerant compressor stops; main alarm relay tripped. 	If possible, reduce the thermal load within design limits. Follow the alarm reset procedure to start up the unit again (Chapter 8 "Electronic control").
D Low pressure switch (LP) trips Alarm displayed: <i>LP 1</i>	D1 Lack of refrigerant in the plant (see also A5).	D1.1 <ul style="list-style-type: none"> Refrigerant compressor stops; the message "<i>LP 1</i>" alternates on the display with the value of BTOWT; main alarm relay tripped. 	Call a qualified refrigeration engineer to check for leaks and replenish refrigerant charge.
E Alarm displayed: <i>EC 1</i> The compressor protection device trips.	E1 Thermal load too high combined with a situation of refrigerant circuit unloaded (also see A5).	E1.1 <ul style="list-style-type: none"> The head and the body of the compressor are very hot; the compressor stops and tries to restart after a short period (even a few seconds). 	Call a qualified refrigeration engineer to check for leaks and replenish refrigerant charge.
	E2 Wrong Scroll compressor rotation direction.	E2.1 The refrigerant fluid is not compressed and the unit doesn't cool.	Invert two phases of the electrical power supply.
F Digital display and all LEDs off although P1 main switch On (I).	F1 Auxiliary circuit fuse tripping.	F1.1 Measuring with a tester the voltage at the transformer secondary winding connector, there will be not tension survey.	Check the causes of the fuse tripping. Replace the fuse.
	F2 Abnormal power consumption by one or more control board components.	F2.1 Despite presence of power at the connectors of the control board, the display and all LEDs remain unlit.	Try to turn the unit OFF and ON again. If this doesn't solve the problem, contact the nearest service centre

Table 27 TROUBLE SHOOTING

PROBLEM	CAUSE	SYMPTOM	REMEDY
G Alarm displayed: <i>E 1, E2 or E3</i>	G1 BTOWT, BEWOT or B3 probes damaged.	G1.1 <ul style="list-style-type: none"> • See problem; • main alarm relay tripped. 	Check that the temperature probe is correctly connected to the control board connectors and that the cable is undamaged. If necessary replace the temperature probe.
H Alarm displayed: <i>HE</i> .	H1 High water outlet temperature. The value set with parameter <i>P 16</i> is lower than the value measured by BTOWT probe.	H1.1 <ul style="list-style-type: none"> • See problem; • main alarm relay tripped. 	Identify and remove the cause of BTOWT temperature increasing to a value higher than <i>P 16</i> .
I Alarm displayed: <i>A 1</i> .	I1 Low water outlet temperature. The value set with parameter <i>A 1</i> is higher than the value measured by BEWOT probe.	I1.1 <ul style="list-style-type: none"> • See problem; • the compressor stops and starts again when the <i>A 1+A2</i> value is exceed; • main alarm relay tripped. 	Identify and remove the cause of BEWOT temperature decreasing to a value lower than <i>A 1</i> .
	I2 Water flow too low.	I2.1 <ul style="list-style-type: none"> • See problem; • the compressor stops and starts again when the <i>A 1+A2</i> value is exceed; • main alarm relay tripped. 	Increase the water flow.

Table 27 TROUBLE SHOOTING



PROBLEM	CAUSE	SYMPTOM	REMEDY
J Alarm displayed: <i>FL</i> pump thermal switch or flow switch tank level (option)	J1 The pump's thermal protection device has tripped because the water flow is too high.	J1.1 <ul style="list-style-type: none"> • See problem; • main alarm relay tripped; • the refrigerant compressor and pump stop; • the message "<i>FL</i>" alternates on the display with the value of BTOWT; • the pressure difference read on the machine gauge with the pump stopped and pump running is lower than the available head with maximum pump flow. 	Reset the thermal protection device. Increase the pressure drop in the hydraulic circuit, for example by partially closing a pump outlet cock.
	J2 The level sensor doesn't detect the presence of water.	J2.1 <ul style="list-style-type: none"> • Water loss in the tank alarm trips; • the unit stops. 	Check the water filling system of the tank.
	J3 Filter upstream to the unit obstructed.	J3.1 <ul style="list-style-type: none"> • The water doesn't flow regularly; • main alarm relay tripped. 	Clean the filter upstream to the unit. Follow the alarm reset procedure to star up the unit again (Chapter 8 "Electronic control").
	J4 Pump protection tripping.	J4.1 <ul style="list-style-type: none"> • Pump protection trips; • main alarm relay tripped. 	Restore the pump protections. Follow the alarm reset procedure to star up the unit again (Chapter 8 "Electronic control").
	J5 The grille through which the pump cooling air passes is obstructed.	J5.1 <ul style="list-style-type: none"> • See problem; • main alarm relay tripped; • the refrigerant compressor and pump stop. 	Reset the thermal protection device. Free the grille.
	J6 The pump is defective.	J6.1 <ul style="list-style-type: none"> • See problem; • main alarm relay tripped; • the refrigerant compressor and pump stop; • the current absorbed by the pump is greater than the nominal rating; • the pump may be noisy. 	Reset the thermal protection device. Replace the pump.
K <i>EPb</i> alarm displayed	K1 Microprocessor initialising error.	K1.1 <i>EPb</i> flashing on display and the unit is blocked.	Turn OFF and ON the unit. If this does not solve the problem, contact the nearest service centre.
L <i>EPr</i> alarm displayed	L1 Microprocessor mistake in storing data.	L1.1 The unit operates correctly, <i>EPr</i> flashing on display, but at the first lack of power supply the configuration of the unit resets.	Turn OFF and ON the unit. If this does not solve the problem, contact the nearest service centre.

Table 27 TROUBLE SHOOTING